



World Wide Trolley Bus Technology Development

**– A Study for Hong Kong
Environmental Protection Department**

Ecotraffic

World Wide Trolley Bus Technology Development

– A Study for Hong Kong
Environmental Protection Department

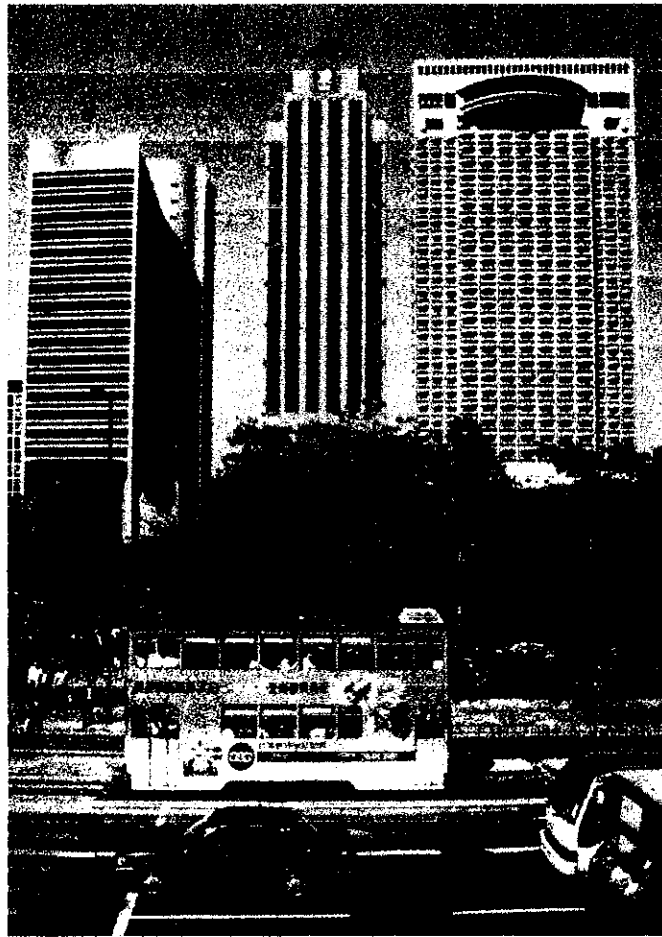

Photo: P. G. Andersson

Ecotrafic
RESEARCH & DEVELOPMENT AB

 **Trivector**
TRAFFIC AB

Preface

In November 1998, Ecotrafic Research & Development AB got an assignment from the Environmental Department in Hong Kong to study the trolley bus systems in other countries.

The study about trolley bus system has been written by Dr. Eng. Per-Gunnar Andersson and M.Sc. Karin Neergaard, Trivector Traffic AB.

During the course of work, we have been in contact with manufacturers of trolley buses as well as of infrastructure. We have also been in contact with five important trolley bus cities regarding their trolley bus system.

Dr. Eng. Åke Brandberg, M.Sc. Peter Ahlvik and Managing Director Bengt Sävbark from Ecotrafic have been responsible for the quality check of the study.

24 March, 1999

Ecotrafic Research & Development AB

Trivector Traffic AB

Contents

1. Introduction	5
2. Literature survey of trolley bus systems	6
2.1. The trolley bus history	6
2.2. Trolley bus systems world wide	6
2.3. The 18 most interesting systems in Western Europe and America	7
3. Trolley bus technology used world wide	14
3.1. Drive-train technology	14
3.2. Vehicle body configurations	18
Manufacturers	24
4. Major trolley bus manufacturers	25
5. Five case studies	29
5.1. Vancouver	29
5.2 Athens	31
5.3 Dayton	32
5.4 São Paolo	34
5.5 Lausanne	35
5.6 The role of the trolley bus	36
5.7 Life time costs	38
6. Conclusions	41

Appendix 1.

Manufacturers of trolley buses

Appendix 2.

Manufacturers of electrical equipment

Appendix 3.

Questionnaire to the manufacturers

Appendix 4.

References

1. Introduction

A growing environmental concern amongst politicians in cities with heavy traffic has contributed to an increasing demand for non-polluting modes of transportation.

The trolley bus system is one alternative that offers a more environmentally friendly transportation. The benefits of the trolley bus is that there is no direct emissions and it is relatively quiet. It can be argued that the infrastructure needed for trolley buses as well as for trams can have a negative visual impact. However, the design and layout of the structures and cables to merge with the background of the street scene will help to reduce the visual intrusion. Moreover, there are also important benefits with a system that is clearly seen in the urban environment. In some cases, this can lead to an increase in patronage. When the layout of the system is clearly seen in the environment people become aware of its existence and can clearly see the route it will follow. The disadvantage with trolley buses is that they have little flexibility in re-diverting routes in the case of traffics of accidents.

The main obstacle with trolley bus is the high initial cost for infrastructure and buses. A trolley bus is more expensive than a diesel bus. On the other hand, the trolley bus is less expensive than the tram. The environmental benefits must therefore be taken into consideration.

2. Literature survey of trolley bus systems

2.1. The trolley bus history

The first trolley bus in the world was demonstrated by Werner von Siemens in Berlin in 1882. The vehicle was a horse-drawn cab equipped with an electrical engine taking power from an overhead wire. After this first test, the high era of trolley buses was just after WW1 and WW2 when there was a shortage in petrol.

Even if the first trolley bus was presented in Germany, it was in Great Britain it expanded most. The trolley bus net in London were one of the greatest (400km), before the shut down began in the 50's. Most trolley bus systems in Europe and the rest of the world were developed in the 1930's-40's. Many systems were abandoned in the 60's, but in the 70's, the oil crisis and the growing environmental awareness led to a renaissance of the trolley bus. Many of the systems that outlived the 60's are still in operation today.

2.2. Trolley bus systems world wide

Today there are about 340 cities in the world with trolley buses. Most of the new systems are found in Eastern Europe and the former Soviet Union. There were 185 systems in former Soviet Union in 1998. Although many cities in Western Europe and America abandoned the trolley bus in the 60's, the trolley bus system is still developing in some cities. The last decade, more than 2 600 trolley buses were ordered to over 100 systems.

In the year 1998, 46 cities in Western Europe had trolley buses. The most important countries with trolley bus in this part of the world are Switzerland with 15 systems, France with 6 systems and Italy with 14 systems. Table 2.1 presents the number of trolley bus systems in different parts of the world.

Trolley buses are used for the flexibility of power supply (electricity from different sources), for running on high over the sea where the air is thin (Quito), in cities with steep gradients (San Francisco) or for environmental reasons (Arnhem and Athens).

Table 2.2.1. Trolley bus systems world wide in the year 1998.

Area	No of systems	Systems under construction
Western Europe	46	
Eastern Europe	58	8
Former Soviet union	185	6
North America	9	
South an Central America	10	
Peoples republic of China	25	
East Asia	8	
West Asia	2	
Africa	0	
Australia/New Zealand	1	

2.3. The 18 most interesting systems in Western Europe and America

The largest system in Western Europe and America is found in São Paulo (Brazil). The public transport system in this city has the largest trolley bus system in counts of length in km and number of buses (see figure 2.3.1).

Below a short presentation of the 18 most interesting systems are made. The systems presented are the largest systems with one small exception for Quito (Equador). There are a few systems larger than Quito, but we have chosen Quito because they have had a fast development of the

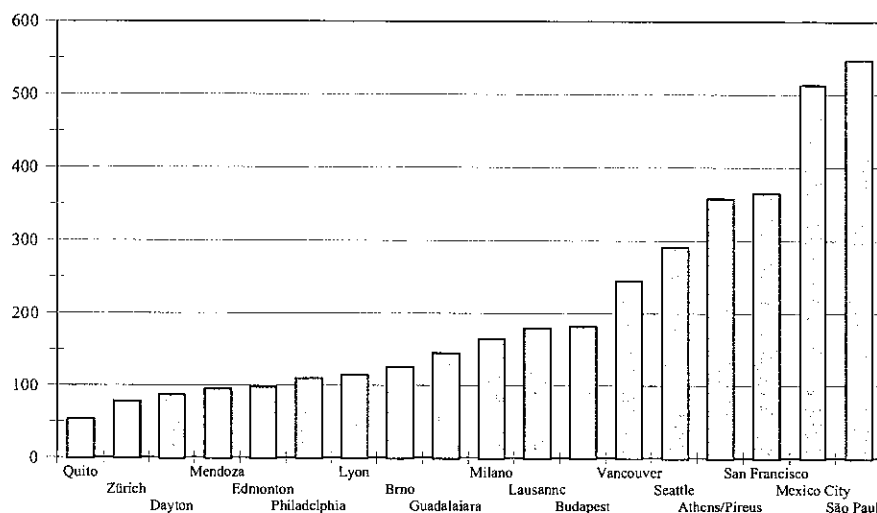

Figure 2.3.1. Number of trolley buses in 18 cities in Western Europe and America.

system. In figure 2.3.1, the 18 interesting systems are presented by number of trolley buses.

It is interesting to note that some of the small cities have a relatively large extension of trolley bus routes. The smaller cities, which are presented below have, naturally, a smaller fleet, but have a long route length compared to the population. Dayton (USA) is one example (see figure 2.3.2) of a small town with an extensive route net. Edmonton (Canada) and Lausanne (Switzerland) also have a fairly long route length in comparison with the population.

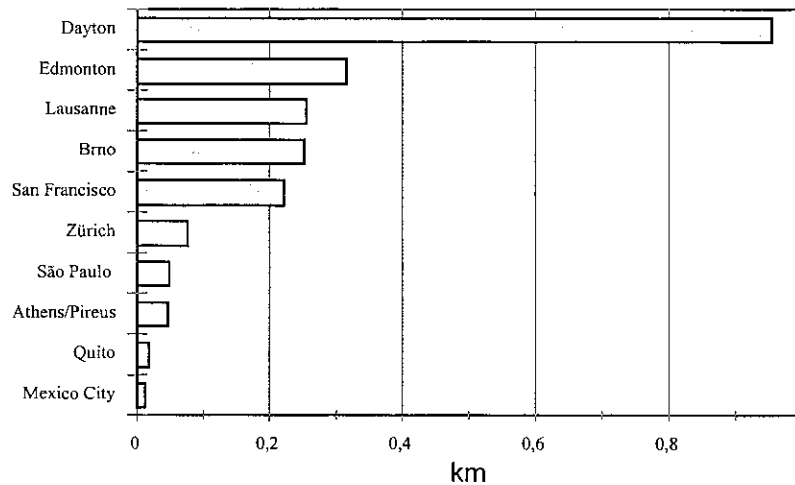

Figure 2.3.2. Route length (km) per 1000 inhabitants.

São Paulo (Brazil)

The largest trolley bus system in counts of km and number of buses is found in São Paulo, with 11 million inhabitants. The trolley bus system service in São Paulo is divided upon two operators who together have 548 buses. SPTrans have 480 trolley buses and 18 trolley bus routes, which altogether range 453 km. The trolley bus system constitutes the backbone of public transport in the city.

The EMTU operates outside the city's boundaries and has 68 trolley buses, which operate on 4 routes ranging 37 km. This network, known as the Medium Capacity Network, opened in 1989/90. (More information in chapter 5).

Mexico City (Mexico)

The second largest trolley bus fleet is found in Mexico City (with a population of 20 million), where 513 trolley buses are operating on a route length of about 200 km. 17 trolley bus routes exist. Travelling by trolley bus have decreased the last decade. In 1989 225 million passenger journeys were made by trolley bus in 1993 the figure was 99 million. This doesn't mean that the system is less interesting. They still invest in it and the last decade they have undertaken a major programme of renovation and expansion of the trolley bus net.

In 1990 the system extended to 30 routes. On account of extended metro facilities some routes have been closed, but still the extension has been greater. In 1995 another new route opened. Construction of a 24 km trolley bus route was announced in early 1997, but after elections the project went into abeyance. During 1997, though, they invested in 50 new trolley buses by MASA/Mitsubishi and they have an order on another 200 to be delivered 1997/99.

San Francisco (USA)

San Francisco has a trolley bus system with 364 trolley buses operating on 17 routes totalling 158 km. The population in San Francisco city is 730 000 inhabitants. The trolley bus system in San Francisco is well used as the amount of vehicle-km is quite high (11.4 million vehicle km in 1996/97). In comparison with the diesel bus journeys, the trolley bus journeys is 85% of those while the vehicle km is 60% of that of the diesel bus.

San Francisco is still investing in the system and will continue to do so. The latest purchase of trolley buses was in 1992 with 60 New Flyer articulated. In 2-4 years, they will replace the rest of the fleet. They may even convert some diesel lines to trolley bus operation.



Figure 2.3.3. Trolley bus in San Francisco (photo: PG Andersson).

Athens/Pireus (Greece)

The urban public transport system in Athens, Greece, serves a population of about 3.6 million inhabitants. The ILPAP, who operates the buses in Athens, have the largest trolley bus fleet in Western Europe. It consists of 357 buses. There are 18 routes totalling 148 km. Most of the routes serve the central business district. As the air quality is very bad in Athens, they have put a lot of effort into developing the trolley bus system. Currently

they have an order on 192 duo buses to be delivered in the year 2001. (More information in chapter 5).

Vancouver (Canada)

Vancouver in Canada has a population of 1.8 million people. All public transport is operated by BC Transit. The trolley buses have operated in Vancouver for 50 years. The fleet consists of 244 trolley buses (for example Flyer) operating on 13 routes. There are 20 rectifier stations and the over-head wire has a length of 305 km.

Vancouver is interesting because they intended to close down the system in the 60's but it survived. Today the system carries one third of BC Transit's revenue passengers in Greater Vancouver. About 70% of downtown Vancouver trips are handled wholly or in part by trolley bus. Every weekday 257 900 riders go by trolley bus. (More information in chapter 5).

Seattle (USA)

The city of Seattle in USA have 531 000 inhabitants. The trolley bus operates on 13 routes in Seattle. The fleet consists of 391 trolley buses, where 236 of them are dual-mode buses (Breda). The overhead infrastructure has a length of 182 km.

Budapest (Hungary)

Budapest in Hungary has a population of 2.1 million people. The public transport is managed by BKV, which was transformed from a state company to municipal ownership in 1996.

The trolley bus fleet consist of 182 buses, which operates on 14 routes of a total length of 69 km. Passenger journeys by trolley bus were in 1996 80.7 million, which represent about 6 % of passenger boardings on all modes. In 1997, Budapest invested in four new trolley buses.

Lausanne (Switzerland)

The population of the Swiss town Lausanne is 244 000 people. It is not a big city, but still as much as 95 trolley buses operate in the town (the fleet has 111 buses). The trolley bus operates on 11 routes, which have a total length of 61 km. Lausanne is, together with Luzern, the only city who operates with low-floor trailers connected to the standard buses.

The trolley buses in Lausanne are quite old, in average 15 years old. They plan to replace the whole fleet by new ones in the year 2000. (More information in chapter 5).

Milan (Italy)

Milan in Italy has a population of 1.5 million people. The ATM is responsible for the trolley bus services as well as the other public transport services within the city boundaries. The 165 trolley buses in

Milan operates on 3 routes with a total length of 40.4 km. 66 of the buses have been purchased in the 1990's. In 1996 47.4 million passengers travelled by trolley bus in Milan.

Guadalajara (Mexico)

Guadalajara, Mexico, with a population of 4 million, has a trolley bus system with 145 buses. There are 4 routes for trolley buses. There have been no investments in new vehicles in the 1990's. In 1995, a new trolley bus route opened.

Brno (Czech Republic)

The public transport system in Brno serves 395 000 inhabitants. The fleet includes 126 trolley buses (Skoda) which operate on 14 routes, on a total route length of 98 km. A new trolley bus depot opened in April 1997 presaging reinstatement of Route 140 currently bus operated.

Lyon (France)

France has several towns with trolley bus systems with quite a long history. Lyon, with a population of 420 000 inhabitants, is one of them. The trolley bus fleet in Lyon has 115 buses (Renault) which are operating on 8 routes with a total distance of 54 km.

The average age of the trolley buses is 16 years. They are refurbishing the fleet continuously and a reserved track trolley bus route is under the construction. A new light rail system is also under development in Lyon.

Philadelphia (USA)

In Philadelphia, a 1.6 million inhabitant-city in USA, the trolley bus system is quite small compared to the bus system. The trolley bus fleet has 110 buses operating on 5 routes with a total length of 34 km.

Edmonton (Canada)

Edmonton in Canada, with a population of 637 000 inhabitants, is one of the towns that are currently investing in the trolley bus system. Today the fleet consists of 98 trolley buses (no duo buses) operating on 7 routes with a total length of 200 km.

The systems future has been in doubt, but in 1994 came a four-year-programme with investments to upgrade the infrastructure. The past decade Edmonton has invested about USD 9.3 million in the trolley bus system. The money has gone into rehabilitation of the overhead wire, poles and hardware, replacement of substation AC and DC switchgear, transformers and rectifiers. There are no current plans to expand the system.

Mendoza (Argentina)

In Mendoza, a town with 475 000 inhabitants, a large number of passenger journeys are made by trolley bus. The fleet has 95 buses and they are operating on 5 routes, on a total length of 50 km.

The vehicles are old, but many of them have been refurbished. Two new sections opened in 1986, another one in 1989. For environmental grounds, they began with a programme from 1991 to eliminate the diesel bus in the city centre. This led to the construction of a 17 km north-south cross-city, completed in 1997.

Dayton (USA)

Dayton, a US-town with 182 000 inhabitants, has a fleet with 87 trolley buses operating on 7 routes totalling 173 km. Passenger boardings on trolley buses, 3.2 million in 1996, constitute about 20% of the total passenger boardings in Dayton. The relation in vehicle-km is almost the same.

RTA, the transit authority, is making extensive investments in the trolley bus system in order for the trolley bus to constitute the heart of the public transport system. Over the next five years, they will make extensive investments in both infrastructure and trolley buses. All buses, except for those purchased in 1996, will be replaced. Today the oldest buses are from 1976 and 77. (More information in chapter 5).

Zürich (Switzerland)

In Zürich, a Swiss town with 360 000 inhabitants, the VBZ is controlling the trolley bus system. The fleet has 78 trolley buses, many of them quite new. They have an order on 15 new Mercedes'. The buses are operating on 6 routes, totalling 41 km.

Regarding developments, they have long-term plans to convert some further four routes to trolley bus operation.

Quito (Ecuador)

In Quito, Ecuador, with a population of 800 000 inhabitants, the public transport system consists of trolley buses and private minibuses. The trolley bus system is quite new, 54 trolley buses with auxiliary diesel engines operate the 11 km of routes since 1995/96. The system is built with separate busway lanes, described as a rubber tyres light rail line, with high station platforms at trolley bus level. The light rail was rejected because of that the vibrations could harm the historic buildings.

The introduction of the trolley bus system is considered as a success and further extensions of the net are planned. At least 22 vehicles have been ordered to be delivered in 1998. Every day 200 000 passengers go by trolley bus.

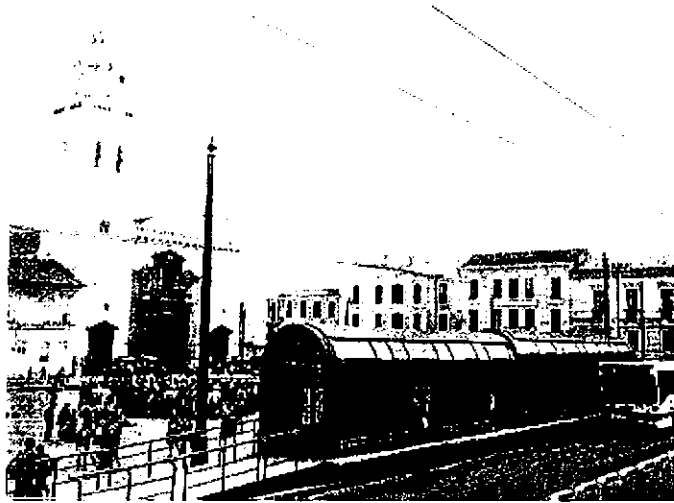

Figure 2.3.4. Trolley bus system in Quito at a high-platform station.

3. Trolley bus technology used world wide

3.1. Drive-train technology

General definitions

Trolley buses are supplied with traction energy from the electric power lines with means of the roof-mounted collectors. Normal feeding voltage from the lines is 600 VDC or 750 VDC. They may also be equipped with a small traction battery package in order to make it possible to drive the bus a very short distance if line power fails or if the collector has lost contact with the power lines. A principal trolley bus is shown in Figure 3.1.1.

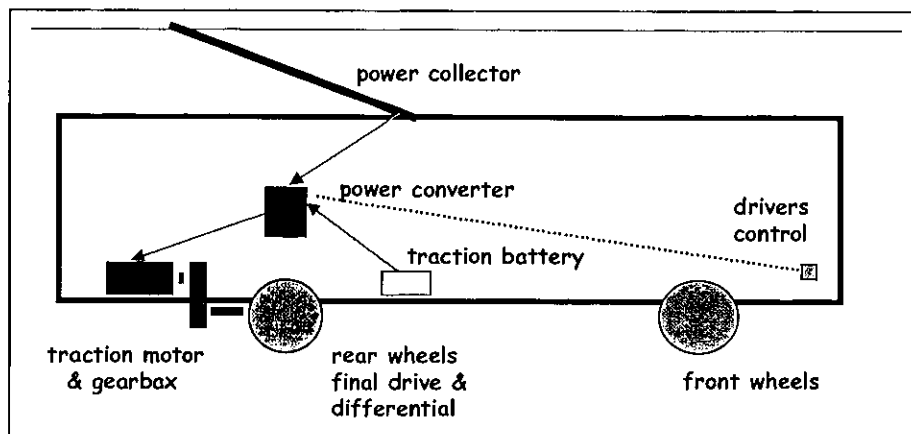

Figure 3.1.1. Principal trolley bus.

Dual mode buses are supplied with traction energy from fossil fuel or biofuel burned in an onboard Internal Combustion Engine (ICE). The ICE propels a generator, which charges the onboard traction batteries. Power from the batteries is then fed to the converter, which feeds driver controlled power to the electric traction motor(s). This system is called a series hybrid system. If the ICE also can propel the bus directly by means of a mechanical clutch or by feeding the electric traction motor directly from the generator (i.e. bypassing the batteries) it is called a parallel hybrid system. A dual mode bus can also be fed with traction energy by means of a battery charger, see below. A principal dual mode bus is shown in figure 3.1.2.

If the traction batteries are completely removed from a dual mode bus, the result may be a diesel-electric bus or a petrol-electric bus etc. This type is of course 100% dependent on the actual fossil fuel or biofuel being used.

If the Internal Combustion Engine and electric generator is removed, the result will be a pure electric bus. Traction energy is then supplied from

the power grid by means of a battery charging system, which can be either an onboard charger or a stationary off board charger.

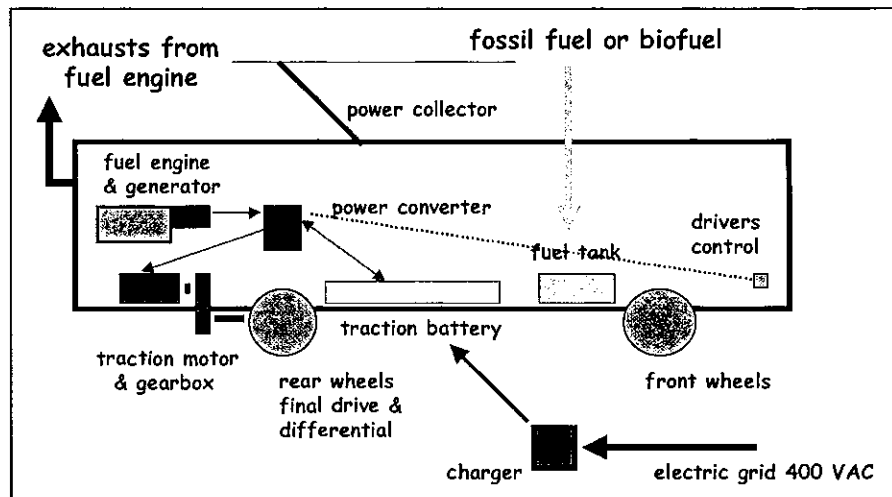

Figure 3.1.2 Principal dual mode bus.

System topography

There are two main different types of electrical motor installations being commercially (or precommercially) available for trolley buses and hybrid electric or pure electric buses today:

- hub motors (or wheel motors) respectively
- chassis mounted motors

Hub motors

The hub motors are directly integrated in the driving wheels and do not need any rear axle with reduction gear and mechanical differential function. The differential function is created electronically by the power electronics. These motors hence rotate with the same speed as the wheel. Both two wheel drive and four wheel drive systems exists. The most well known manufacturer of this type is the company Magnet-Motor GmbH in Germany. A principal hub motor installation is shown in figure 3.1.3.

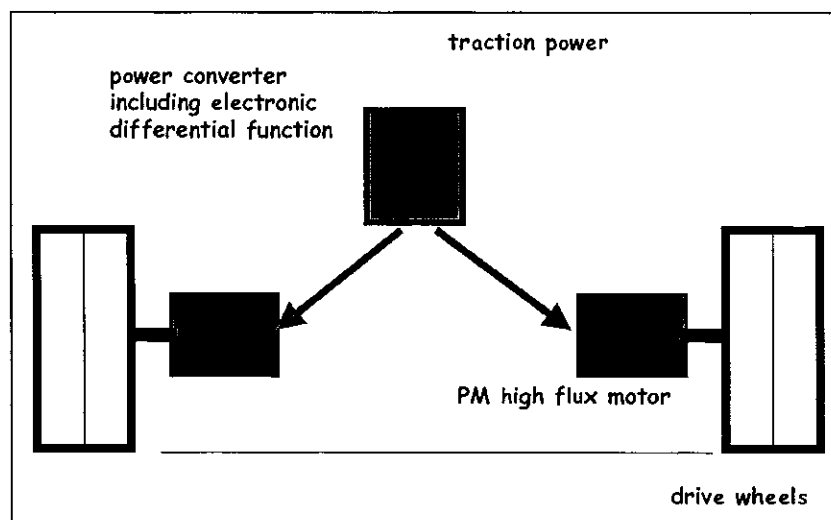

Figure 3.1.3. Principal hub motor system.

Chassis mounted motors

Chassis mounted motors are however more common. They are normally used in combination with a rear axle with reduction gear and a mechanical differential. Either one single motor directly connected to the propeller shaft, or two identical motors connected to the propeller shaft via an intermediate gearbox can be used. Several manufacturers such as Skoda (CZ) and Ansaldo (I) use this design. A principal system is shown in figure 3.1.4.

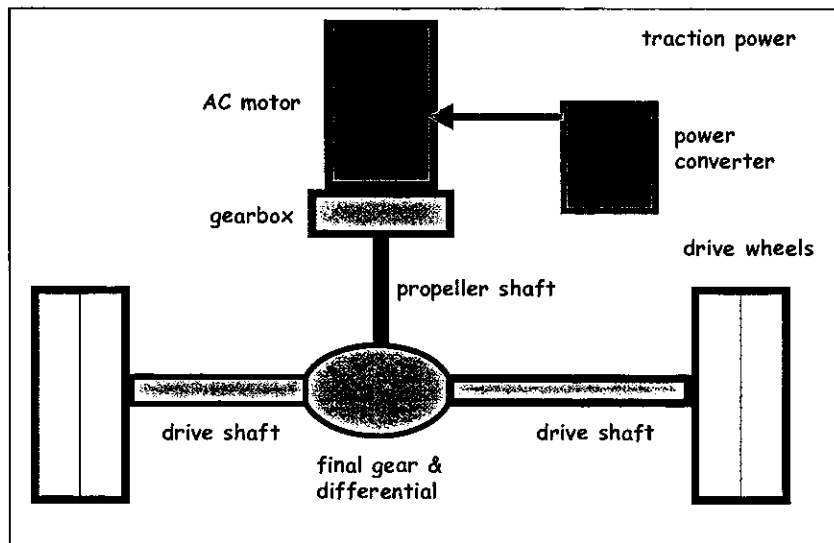

Figure 3.1.4. Principal chassis mounted motor system.

The ELFA-system

A special design is made by Siemens of Germany with their Electric Low Floor Axle (ELFA), which can be regarded as a compromise between the two main types hub motors respectively chassis mounted motors. It consists of a live rear axle with two integrated motors, each of them working together with a two step reduction gearing. See figure 3.1.5.

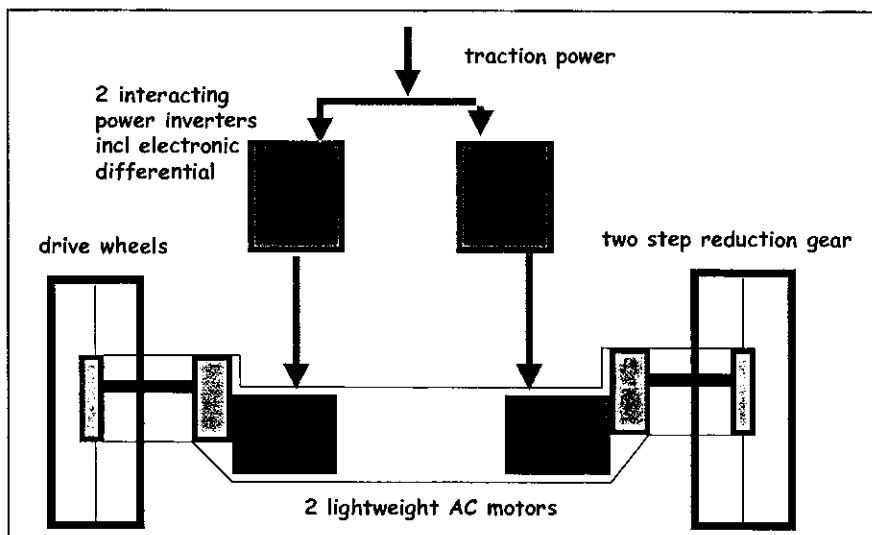

Figure 3.1.5. Principal of electric low-floor axle (Siemens).

Different types of electrical motors and power electronics

In addition, different types of electrical motors and power electronics are being used. The main types are:

- high speed AC induction motors fed by IGBT converters (transistors)
- DC traction motors fed by GTO pulse converters (thyristors)
- PM high flux motors fed by IGBT converters

A special type of power electronics is the combined power converter/battery charger. This concept is possible in hybrid or pure electric buses and if a three phase AC traction motor is used. By designing the power electronics in an intelligent way, the components can be used both for the converter function and as an onboard charger.

General comparison between different drive systems**Low floor chassis**

A main feature of modern buses is a low floor chassis enabling easy embarkment and disembarkment. The hub motor system is best adapted to this requirement and the Siemens ELFA system second best. With chassis mounted motors it is difficult to obtain a full low floor bus. Using two smaller motors instead of one big is one way of compensating for this, even if the result never can be as good as with hub motors.

Lifelong and maintenance

The predominant design for trolley buses has been DC motors with thyristor converters. This is a straightforward technology representing a robust and easy to control and to repair system. However, it also requires a certain level of routine maintenance, mainly focused on the motor brush system. The level of maintenance for this type of system is expected to be higher in comparison to well designed modern AC motor and PM high flux motor systems.

A factor mainly influencing lifetime and level of maintenance required is the type of cooling used. An efficient water or oil cooling system for both traction motor and power electronics is very positive in this respect. The hub motor type drive system is very dependant on efficient cooling since the motors have a low rotational speed and also are cut off from ambient air cooling.

Another factor is of course the complexity and number of moving and interacting components in the mechanical part of the drive system. In this respect, the hub motor system is most favourable.

System performance

The performance of the traditional DC motor system in terms of power/weight ratio and torque/weight ratio and in terms of smooth operation is surpassed by the more modern AC motor systems and especially by the PM high flux motor (hub motor) systems.

Spare parts and service

In general, it can be expected that the more commonly used a system is, the more easy it will be to obtain spare parts and service. This will favour a drive system based on chassis mounted motor(s) with conventional rear axle and differential and a well proven AC motor drive system based on well established industrial components. Nevertheless, the level of mechanical maintenance of such a system will probably be higher than for a well designed hub motor system. On the other hand, a more exclusive system such as the hub system may require more critical components in stock because of long delivery time.

Investment cost and life cycle cost

This has to be evaluated depending on quoted prices and design parameters in comparison to required performance as well as financial parameters. A high investment cost may be compensated by lower maintenance cost and/or better performance.

Conclusions

The hub motor system is the most modern design and has the potential of being the best alternative for future systems in terms of both performance and life cycle cost. Since this technology is relatively new, there is, however, no extensive long time experience from systems used by bus operators. The hub motors are the most expensive and critical part of this system. But if a well designed system, with acceptable construction margins relative actual requirements from daily operation is chosen, this may be the best choice even if investment costs are higher than the traditional DC-systems. An interesting compromise may also be the ELFA system with well proven components.

3.2. Vehicle body configurations

The different vehicle body configurations that are offered are:

- standard two-axle buses,
- articulated buses (three-axle)
- low-floor two-axle buses
- low-floor articulated buses

The standard buses are about 12 m long and have a capacity of 85-100 passengers. They have 2 or 3 doors.

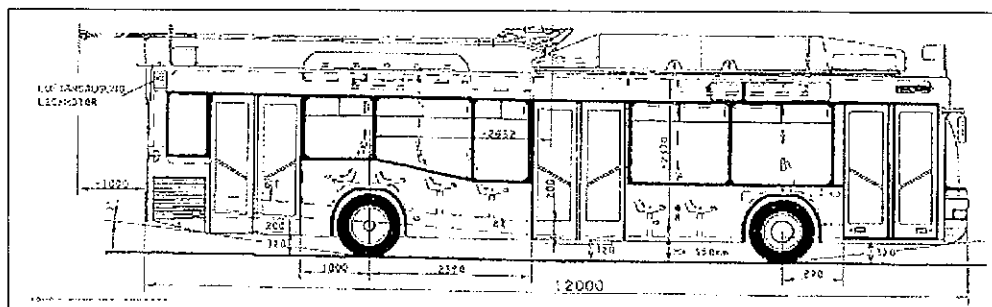

Figure 3.2.1 Standard low-floor trolley bus (model from Neoplan).

The height of the buses are about 3 to 3,5 metres and the width 2,5 metres (see figure 3.2.2) Today most of the manufacturers offers low-floor trolley buses. The floor level is about 350-360 mm, which can be reduced by so called "kneeling". Many manufacturers also offer options like ABS, ASR, kneeling/lifting system and wheelchair ramp.

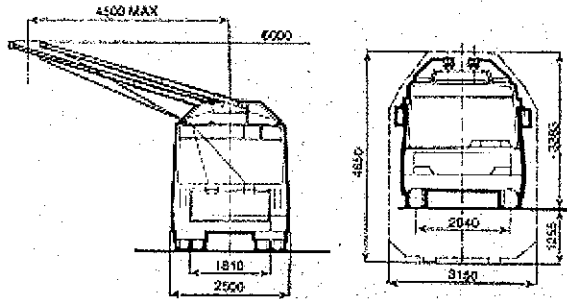

Figure 3.2.2. Dimensions of a Skoda low-floor trolley bus (22tr).

The articulated buses are about 18 m long and have a capacity of 140 passengers (see figure 3.2.3). They have 3 or 4 doors.

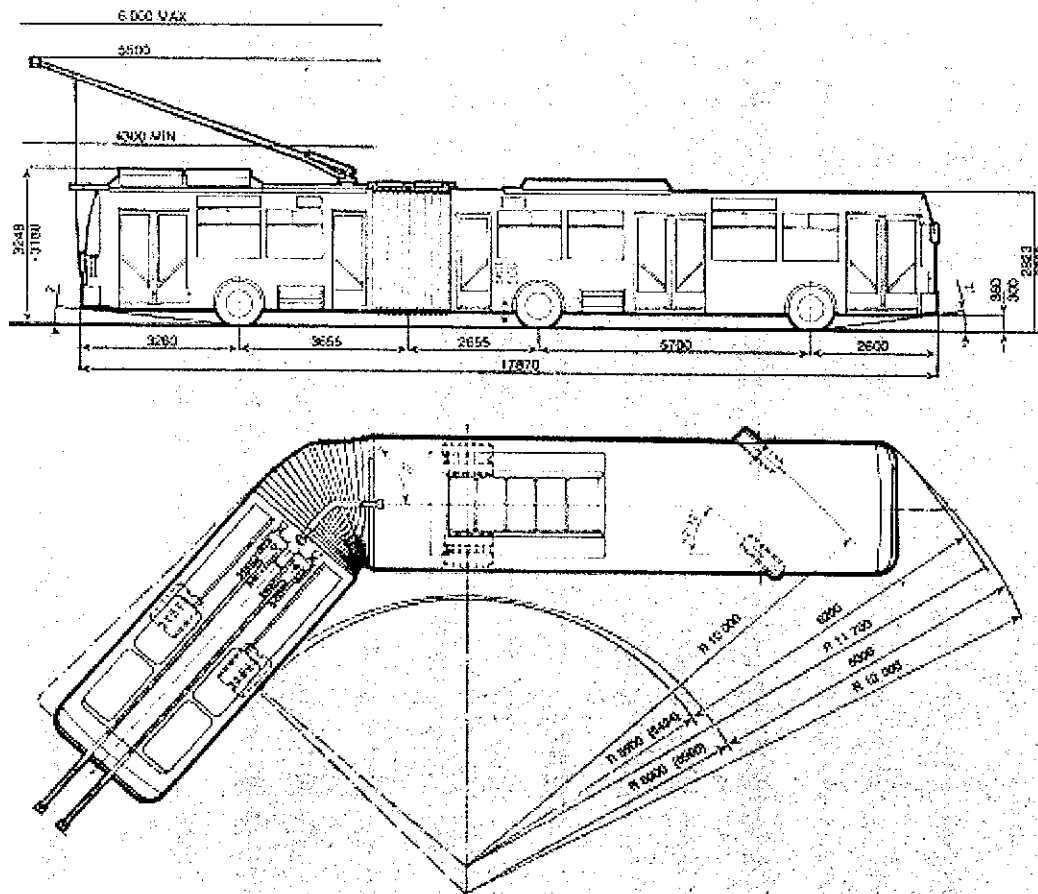

Figure 3.2.3. Dimensions of the low-floor articulated Skoda bus (22tr).

Double deckers are not in use for trolley bus systems. According to the manufacturers, it is problematic to build a double decker trolley bus as the electrical components require space on the roof and it will be problematic with the electric drive. It would be easier to realise a double or triple articulated single decker trolley with 24 m or 30m in length.

Trolley buses with dual mode are in use in several cities today. There are also dual mode buses. The dual mode vehicle has both a diesel engine and an electric system.

The climbing performance of a trolley bus is 11-13%, the gradient for a dual mode the same and in diesel mode about 15%.

Attachment to or disconnection from the overhead wires is effected, for practical reasons, at bus stops. During this process, the bus may not be in driving mode. At the attaching point, two funnels are installed on the power transmission lines. They guide the rod into contact with the power lines. Disconnection is not limited to any specific place. After the rods have been lowered, they are fastened in a fork-shaped frame at the rear end of the vehicle roof.

3.3. Overhead wire system

The power supply system for a trolley bus system is in all-important parts similar to the power supply for a tram system. It consists of substations with transformer and rectifier, carrying system and overhead contact wire. For trolley bus systems as for tramway systems 600 V DC or 750 V DC is used. The reliability of the diode rectifier is good, according to the cities contacted in the study. The newer ones are more reliable than the old ones. As for the thyristor technique, it is still quite new.

The rectifier stations can be put inside a normal building, for example in the cellar. For the personal security, the building has to have good evacuation possibilities.

Transformer and rectifier

The AC current is converted to 600 or 750 V DC in the rectifier station, which together with the transformer and the control system is located in a substation. There are two types of rectifiers: one based on the diode technique, the other a so-called thyristor rectifier.

Diode rectifiers

The most well-known type of rectifier, which is normally used, is based on a silicon diode technique and is exactly the same as for a tramway system. The transformer is normally connected to the 10 kV AC system in the city. The current is transformed and rectified to 750 V DC. With 800 kVA input the transformer and the rectifier can produce 1000 A 750 V

DC. This is enough for 8 buses fitted with energy regeneration on a 3,5 km section.

Thyristor rectifiers

The latest development in the power supply area is the controlled rectifiers, also named thyristor rectifiers. The advantages of the thyristor rectifiers, in comparison to the standard diode system are: energy savings by reduction of losses in the DC traction network, energy savings by regeneration of braking energy and reduced construction costs due to the considerable lower number of substations needed.

A conventional diode rectifier system can not recover and regenerate any excess energy from the DC-traction network to the feeding AC-network. The energy regenerated can be recovered only by other buses consuming power. A thyristor rectifier system, however, can recuperate the energy gained from regenerative braking to the AC-network.

Number of substations

The number of substations and the distance between them is based on the planned headway for the system. In central areas with many trolley buses, there is a need for more substations than in the suburbs. The number of substations is normally reduced by 30-40% with a thyristor rectifier. New thyristor rectifiers can also be used in combination with existing diode rectifiers.

Cost

The price of a power supply station with diode rectifier for 8 buses is about (1000A) 0,3 million USD. The power station needs to be about 40-70 m² and about 3.5 metre high. It can be installed in a cellar of a building but normally it is placed in a building of its own. A thyristor rectifier is about 60% more expensive than the diode rectifier, but the difference is paid off in 2-3 years, according to Adtranz. Most big manufacturers of electric equipment such as Siemens, Adtranz etc can build a power supply station.

Carrying system and poles

In city centres, the carrying system normally consists of wires tensioned between house walls on both sides of the street. In suburbs and other house less areas the carrying systems is based on poles of concrete or metallic. Poles can be placed on one or both sides of the road. How many carriers needed per km overhead wire depends on the chosen suspension system, the tensile load of the contact wire and type of contact wire. Generally, the maximum distance between carriers is 30 metres.

The problems with poles are that you have to avoid cables and tubes for electricity and water supply. Therefore the use of poles can be very cost intensive especially in an urban street environment. To use the outer walls of surrounding buildings generally reduce the cost to 1/10 in comparison to using poles. By avoiding poles, the negative visual impact is also mitigated. Hence, if the outer walls can not be used one should consider

the possibility of combining street lighting poles and poles for the carrying system.

The carrying wire is used to hold the contact wire. In modern systems, it is made of synthetic fibre (kevlar). Compared to conventional systems it is smaller and has a more aesthetic design. It is also self-insulating and it can be used for all the different types of catenary systems, rigid, semi-flexible and fully flexible pendulum systems. All parts are corrosion-resistant (except for curve rails). The wire system will look less complex and is harming the environment less than ordinary metal wires with insulators.

Overhead contact wire

The carrying system holds the contact wire, switches, crossings etc. This is the only part that differs between a tramway system and a trolley bus system. The contact wire consists of two wires (+ and - DC) with a distance of 0,6 to 0,7 m for each direction. The contact wire of copper has a nominal cross-section of 107 mm² and the weight is 934 kg per km wire. The cross-section depends on the quantity of the current. The wire is placed about 5 m above the driving surface.

Suspension system

The contact wire is connected to the carrying wire with a suspension system. There are mainly three types of suspensions systems. Rigid suspension for low speeds, semi-flexible suspensions and flexible pendulum suspension. The pendulum systems is the one which is usually used today (figure 3.3.1).

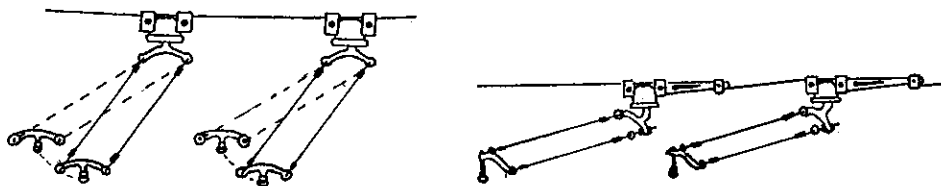

Figure 3.3.1. Pendulum system.

There is also a need for section insulators between the different power supply sections. The insulators are placed at the feeding points. There are more feeding points on every power supply section.

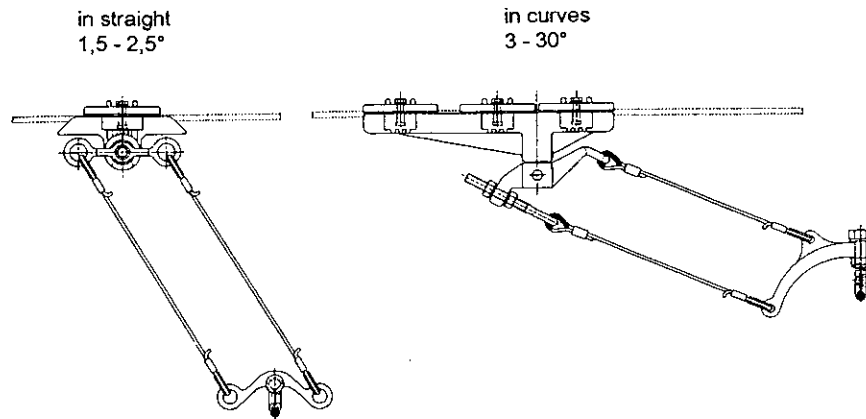

Figure 3.3.2. Suspension system from Kummler+Matter.

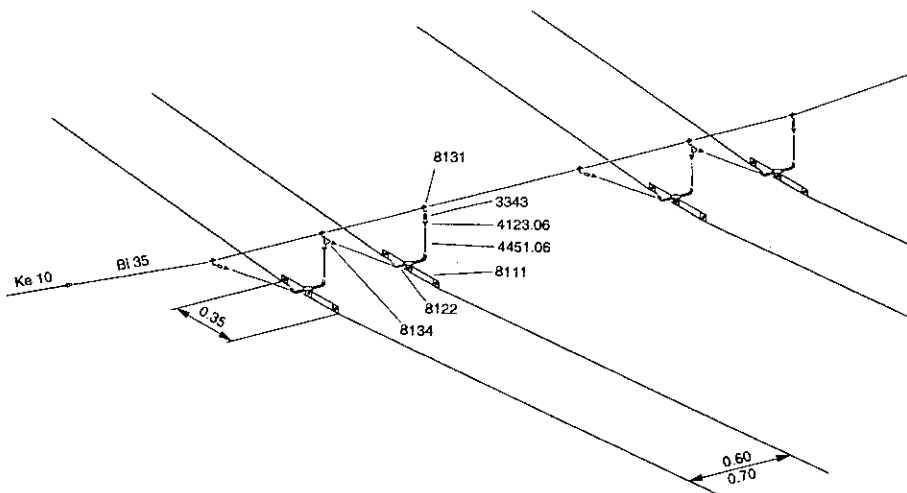

Figure 3.3.3. Suspension system from Furrer+Frey.

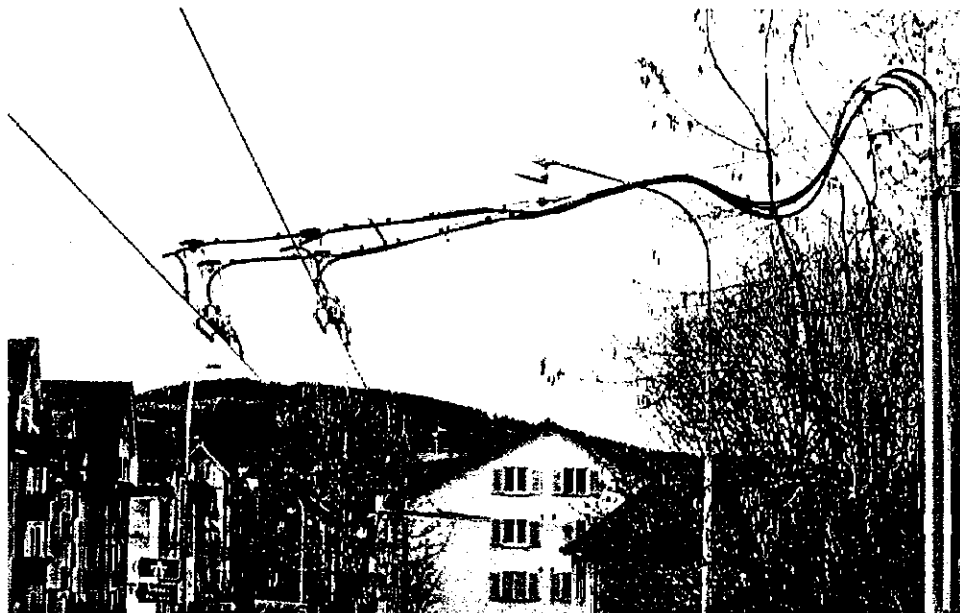

Figure 3.3.4 Feeder point with section insulator (Source: Furrer+Frey).

Switches

The overhead wire for a trolley bus system is the same as for a tramway with trolley pole (such as Hong Kong). The difference is the intersections where the trolley bus needs two switches and one crossing for the wires. This makes it more difficult and more expensive to build trolley bus overhead compared with tram. A normal switch allows a maximum speed of 50 km/h straight and 25 km/h in the turnout. The new types of switches offer greater safety against dewirements and it is possible to get high-speed switches for 60 km/h straight and 45 km/h in the turnout.

A normal switch costs about 8 200 USD and a high speed one costs about 10 000 USD. In crossings there is also need for special equipment and it costs about 6 300 USD each. (A normal crossing between two lines need four crossings which make a total of 25 000 USD). The problems with dewirement are minimised with the newer equipment. The most important, however, is that the equipment is properly installed. BC Transit in Vancouver in Canada has estimated the cost of damaged equipment due to dewirements to 160 000 USD annually (which includes the cost of new equipment and labour for repairs).

To be able to drive a trolley bus the drivers will need some instruction regarding the system apart from the normal knowledge of driving a bus. This is not very difficult, the education can take from a day to a week depending on the local traffic rules etc.

A complete overhead system with poles and double track overhead (4 wires) costs between 0,3 and 0,4 million USD. The lower price is for straight routes and the higher for routes with many curves. If there are a lot of switches and crossings on the route, the costs will be even higher.

Trolley bus and trams

It is possible to run trolley buses and trams with trolley poles on the same overhead wire (+). The trolley bus will need an additional wire as it demands two wires. If there are any plans for trolley buses in the same streets as the Hong Kong tramway they can use the same wire. This was used in St Etienne in France until they changed to pantograph on their trams 2-3 years ago.

Manufacturers

There are two big builders of overhead wire systems for Trolley buses in the world. Both companies are situated in Switzerland. They are Kummler+Matter in Zürich and Furrer+Frey in Bern. Kummler+Matter has built overhead systems in Innsbruck, Salzburg, Esslingen, Bologna, Ancona, Gent, San Francisco, Boston, Budapest and Quito etc. The company Furrer+Frey has built the trolley bus overhead in Fribourg, Neuchâtel, Modena, St Gallen, Solingen, Bern etc.

4. Major trolley bus manufacturers

Most of the manufacturers are located in Western Europe (9) and Eastern Europe (7). In Russia, there are one company building trolley buses and in North America, there are three. In Central and South America, there are also three manufacturers of trolley buses. In Asia there are 3, divided to China (2) and North Korea (1). All bus manufacturers are co-operating with other companies concerning the traction equipment. The most companies producing traction equipment are located in Europe. Outside Europe, there are companies in USA, Japan and Russia.

For the electrification, there are 10 companies in the world, most of them located to Germany or Switzerland. The development of the overhead wire and the switches are still in progress. The result is that to day it's possible to run through an overhead switch in 80 km/h with a trolley bus.

For further information on the developments and standards on trolley buses today, we have contacted the following manufacturers:

AAI Transportation Systems	USA
Breda Transportation Inc	USA
New Flyer	USA
Skoda	Czechoslovakia
Neoplan	Germany
MAN (ÖAF Graf & Stift)	Germany
Hess	Schweiz
Ikarus	Ungary
Mercedes-Benz AG	Great Britain
Iveco	Great Britain
Van Hool	Belgium

For information on trolley bus traction equipment, we have contacted the following manufactures:

Adtranz	USA, Sweden
GE Transportation Systems	USA
GM Hughes	USA
Ansaldo	Italy
Brush	Great Britain
Kiepe elektrik	Germany

For information on electrical equipment for overhead system and substations, we have contacted the following manufacturers:

Adtranz	Sweden
Arthur Flury	Switzerland

Furrer+Frey	Switzerland
Kummler+Matter	Switzerland
Pirelli	Germany
Siemens	USA
Spie Enertrans	United Kingdom

Trolley bus types

Standard two-axle and articulated trolley buses are delivered by Skoda, Neoplan and Ikarus. Many manufacturers today have low-floor buses as a standard type. Low-floor two-axle trolley buses and articulated are manufactured by Van Hool, Hess, Ansaldo Breda, ÖAF and Skoda (see figure 4.1.1). Neoplan manufacture each bus individually in accordance with the request of the client.

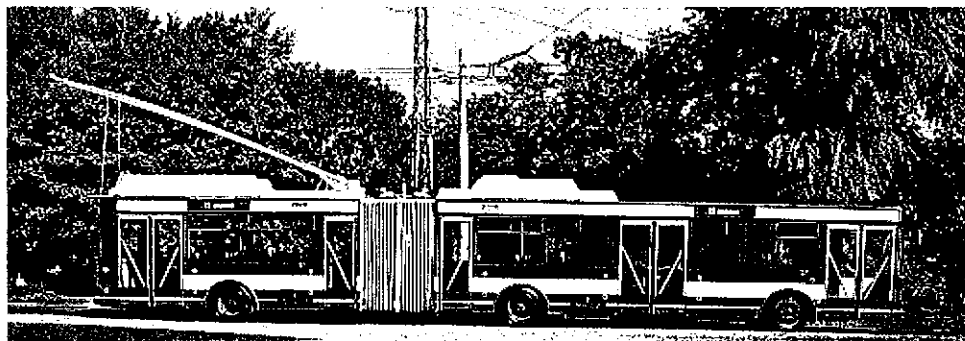

Figure 4.1.1 Skoda's low-floor articulated bus model (22tr).

The drive train technique differs a bit between the companies. For example, Van Hool uses 600 volt three-phase technology with IGBT inverter. Skoda uses 600-759 volt technology with GTO thyristors. Neoplan often use wheel-hub motors, but also a standard electric motor. Ikarus uses a standard electric motor with thyristor control.

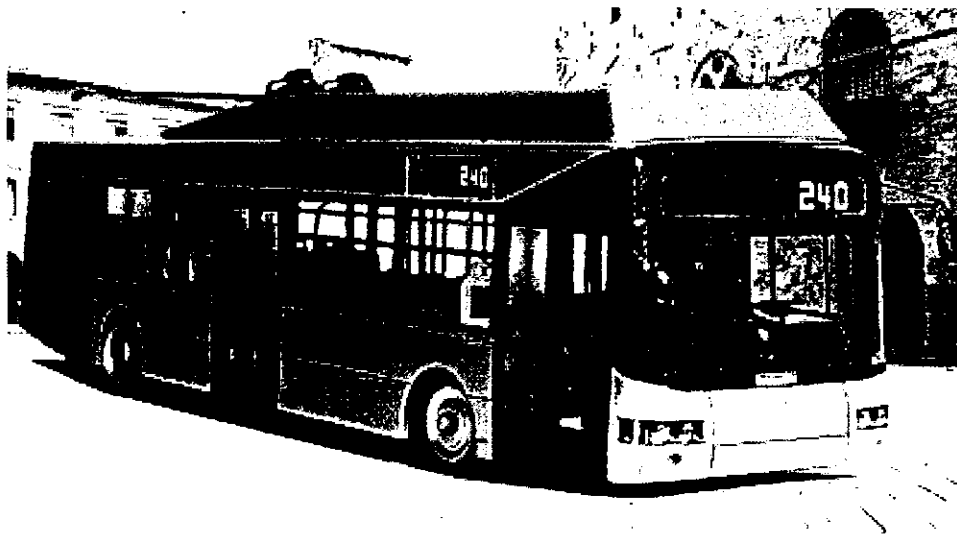

Figure 4.1.2 AnsaldoBreda's low-floor bus (M240).



Figure 4.1.3. ÖAF:s low-floor articulated trolley bus.

Dual mode

Dual mode (also called bimode) is offered by Van Hool, Ansaldo Breda and Neoplan. The dual mode vehicle has both a diesel engine and an electric system. Van Hool offers catenary or diesel-electric dual mode bus. Neoplan's dual mode vehicles are made with wheel hub motors. Breda, who has delivered many dual mode buses to Seattle, use a frequency variable type Iverter (AEG Westinghouse). The battery charger is 700 VDC. Bredas dual mode works as follows: in diesel mode, power is applied to the third axle through an automatic transmission whereas in the electric mode, power is applied to the second axle. The mode switching takes less than 20 seconds.

Double deckers

No company delivers double decker trolley buses or have it as a model. Many of the manufacturers are not interested in building any double deckers, as it is too complicated. In the case of a considerable quantity a few can possibly investigate the question (i.e. Ikarus, who has manufactured the ordinary diesel-fuelled double deckers for Hong Kong). According to the manufacturers one problem is that all the electrical components normally are located on the roof and thus require extra space there. The electric drive can also be a problem. A double or even a triple articulated single decker trolley, with 24 metres or 30 metres in length, would be easier to realise.

Costs and expected life time

In general, the price of a trolley bus is almost double the price of a diesel bus. The cost of a standard two-axle bus varies from 0,2-0,6 million USD. An articulated bus with a standard electric motor cost 0,3-0,8 million USD. The same bus with hub motors costs about 1,1 million USD. The extra cost for a low-floor bus is about 50% of the cost for the standard bus. Many buses have low-floor as standard today. The price of these

buses lies in the upper range (0.6 million USD). The lower price, 0.2 million USD, is for the cheapest model, a high-floor standard 2-axle from Skoda. A low-floor model from Skoda costs about 50% more than a high-floor one.

A dual mode bus is more expensive, the price for an articulated dual-mode bus is about 1,2 million USD.

Expected lifetime of the trolley bus is 12 to 23 years, it depends to a very large extent on service and operating conditions. In general, the life expectancy of trolley buses are ten years more than that of a comparable diesel bus. Skoda estimates that the lifetime costs of trolley buses are compared to normal diesel buses approximately 30% higher.

In section 3.3, some costs on the infrastructure were presented. As the cost depends very much on the alignment of the system, traffic intensity etc., it is impossible to make a more thorough estimation of the costs at the moment.

5. Five case studies

From the 18 systems presented in chapter 2 we have chosen five of them for a more detailed description: Vancouver in Canada, Athens in Greece, Dayton in USA, São Paulo in Brazil and Lausanne in Switzerland.

Vancouver is interesting because they intended to close down the system in the 60's but it survived and has developed since then. Athens is interesting as they have developed there system much lately for environmental reasons and has the largest trolley bus fleet in western Europe. Dayton is a small town with an well-extended trolley bus system in comparison to the population. The Swiss town Lausanne also has a relatively large extended trolley bus net and is one of the many cities with trolley bus in Switzerland. São Paulo has the largest trolley bus system in Western Europe and America.

Table 5.1.1. Key facts about the five cities in the case study.

City	Population (million)	Trolley buses	Length (km)	Passenger share in public transport system
Vancouver	1,8	244	306	1/3
Athens	3.6	357	148	1/6
Dayton	0,18	87	173	1/5
São Paulo	11	480	453	No information
Lausanne	0,24	111	61	2/3

5.1. Vancouver

System

Vancouver in Canada has a population of 1.8 million people. All public transport is operated by BC Transit. Bus and trolley bus operations are financed by: 50% fares, 18% local tax sources and 32% subsidy/grants. The trolley buses have been in use for quite a long time. In august last year 1998, Vancouver celebrated the 50th anniversary of the trolley bus.

Today, the fleet has 244 trolley buses (for example Flyer) operating on 13 routes. The fleet has no duo buses and no double deckers. There are 20 rectifier stations and the trolleys run on a network of 306 km of overhead power distribution catenary. BC Transit expends about 2,2 million USD a year in maintaining the overhead and rectifier stations. The trolleys currently use DC Chopper technology. They operate on 600 volts DC.

The system carries one third of BC Transit's revenue passengers in Greater Vancouver. About 70% of downtown Vancouver trips are handled wholly or in part by trolley bus. Every weekday 257 900 riders go by trolley bus.

History

The city of Vancouver was almost completely developed when the trolley system was introduced in the end of the 1940's. The large size of the system created economies of scale in operation and maintenance. The topography is of advantage for the trolley bus as it is operating on hilly routes. The trolley bus fleet peaked in the mid-1950's, but in 1960, there were plans, like in many other cities, to phase out the mode and convert to diesel. Since a decision wasn't made until the 70's, the rising fuel prices together with peoples environmental awareness, contributed to a renaissance of the Vancouver trolley bus system. In the mid 1970's new vehicles were bought and in 1982/83 the fleet was renewed by 245 standard length Flyer vehicles. In the 1980's the trolley bus system extended on many routes. In 1988, for example, it was expanded to include the University of British Columbia.

Development

In the last ten years, BC Transit has not added significantly to the trolley bus system network.

In 1992, the trolley system's original mercury arc rectifier stations were replaced with more efficient and less hazardous solid-state rectifier stations. The replacement cost 3.2 million USD. The programme was completed in 1994 and resulted in a 9% reduction of electricity consumption.

A Trolley bus Improvement Programme (TRIP) was put up in 1996, which have resulted in that over 200 vehicles have been weatherproofed and 13 substations upgraded.

Other improvements are the replacement of wood traction poles with steel and the incremental upgrading of the overhead infrastructure, which have resulted in higher speed and reduced dewirements. The overhead in Vancouver is generally being actively maintained. New trolley overhead maintenance trucks have been purchased at cost of 800 000 USD. The road network have not been significantly upgraded, except for last year when they made a route alignment (130 000 USD).

There are no new trolley buses on order currently. According to BC transit's ten-year –plan the fleet will be renewed between 2002 and 2005. However, the fleet will be reduced from 244 today to 225 in 2002-2005, because of the introduction of a light-rail transit. Even with the reduced fleet size, some service increases on the remaining trolley routes will increase according to BC Transit. They will probably introduce a number of articulated trolleys on higher density routes.

Benefits and problems

A major problem Vancouver has had with the trolley is the maintenance of the old DC chopper technology. The design of the Flyer trolleys they have exposes some of the critical components to adverse weather

conditions, particularly wet snow. They are maintenance intensive. There is also the continual effort to replace overhead wires that are damaged due to automobile or other accidents.

Other disadvantages is that today the trolley buses are not accessible for the handicapped and they have little flexibility in changing or modifying routes.

The benefits of the trolleys are that there is no harmful exhaust emission, they are relatively quiet, and they have good acceleration under load.

Costs

The total cost of operating the trolleys (less operator wages) is about 0,75 USD per kilometre. This is high compared to an equivalent cost for diesel buses at about 0.31 USD per kilometre. The costs include maintenance of the vehicle and overhead and electricity for the trolley bus respectively diesel for the diesel bus. The trolley overhead maintenance cost is about 0,20 USD/km and electricity is about 0,10 USD/km. Diesel fuel cost is 0,16 USD/km. The cost of dewirements is, as mentioned in chapter 3.3., estimated to about 160 000 USD annually.

Any introduction of the trolley, if the infrastructure did not exist, would be problematic according to Chris Lythgo at BC Transit. The barrier is the large relative capital costs required which are exacerbated by a probably higher life-cycle cost than for diesel buses.

5.2 Athens

System

The urban public transport system in Athens, Greece, serves a population of about 3.6 million inhabitants. The ILPAP, who operates the buses in Athens, have the largest trolley bus fleet in Western Europe. It consists of 357 buses, no duo buses. There are 18 routes totalling 148 km. Most of the routes serve the central business district. The operating costs are financed by: 28% fares, 24% other commercial sources and 48% government subsidy/grants.

In 1995, 95 million passenger journeys were made by trolley bus and the vehicle-km is 11 million (1995). A comparison between passenger journeys made on trolley buses and the ones made in the whole public transport system in Athens show that about 16% of passenger journeys are made on trolley buses. The average speed of a trolley bus is 11 km/h. Most of the trolley buses operates in the central districts, which explains the low average speed.

Development

The huge amount of emissions in Athens is one of the main reasons for the development of the trolley bus system. Environmental investigations presented at a seminar in 1990¹ showed that the diesel buses in Athens contributed to 20-40% of the air pollution. This investigation led to a plan aiming to replace diesel bus with trolley bus and the system is now extending. In 1995, several route extensions and alterations were made. New trolley routes are at present in planning and construction stage. Three new routes are under construction in the areas of Petralona, Nikea and Haladri.

A contract has been signed between the trolley bus company and a Greek-European consortium for the building of 192 duo trolley buses. Today, they have no duo trolley buses. They will be delivered in stages up to year 2001. They will be financed by loans and barter deals.

Problems and benefits

The main problems with trolley buses according to Takis Kontoyannis in Athens are that failure of power causes general disruption of the service, that the trolley can not pass traffic obstacles and the high capital cost for the vehicles and infrastructure.

The failure of power seems to be a problem mostly connected to the older equipment. A proper installation is another important factor. According to BC Transit in Vancouver, Canada, they have no problems with failure of power.

The main benefits mentioned are that they are pollution clean, they have a "good image" to the public and that the vehicles have a longer life length.

Costs

The trolley buses, in comparison to the thermal buses in Athens, have higher operating cost but lower maintenance cost. No detailed information about cost comparisons between diesel and trolley buses has been available.

5.3 Dayton

System

In 1997/98 Dayton, a US-town with 182 000 inhabitants, had a fleet with 87 trolley buses operating on 7 routes and 173 km. Passenger boardings on trolley buses, 3.2 million in 1996, constitute about 20% of the total passenger boardings in Dayton. The relation in vehicle-km is almost the same. The average speed of the trolley buses is 17 km/h compared to the

¹ Transport and Environment in Developing Countries, proceedings of a seminar in Sussex, England 10-14 sept 1990.

diesel buses average speed of 23 km/h. The difference is explained by the fact that trolley buses often operates in central districts.

Development

RTA, the transit authority, is developing the trolley bus system in order for the trolley bus to constitute the heart of the public transport system. They are making extensive investments in both infrastructure and vehicles for electric operations. Over the next five years (from today, 1999) the RTA will invest nearly 36 million USD in electric infrastructure and just over 24 million USD on the purchase of 54 new trolley buses. The new buses are manufactured by Electric Transit Inc (a joint project of Skoda and AAI). These 54 new vehicles, plus three vehicles they have had since 1996, will replace all older trolley buses in the fleet.

Fifteen extensions totalling 170 km are planned for opening in phases by 2010. They are also developing the system to bring the trolley buses into the new regional hubs. A 5km extension is under construction in the western parts to replace the diesel bus and further constructions to regional hubs are planned in the near future. Refurbishment of 80% of the overhead is in progress for 1999 completion.

Benefits and problems

The problems related with the trolley buses that RTA has had is occasional breakdowns and that the older trolleys with no off-wire capabilities cause interruption in traffic when there have been an accident. The new vehicles, however, have limited off-wire capabilities and can easily move around an accident. According to the RTA the trolleys are less prone to experience mechanical problems than diesel buses.

The RTA is very positive towards the trolley buses. A resolution from 1991 from the board of trustees clearly defines the goals and benefits of investing in the system.

Costs

The trolley buses are more expensive than diesel buses to purchase, but RTA's trolley buses have an average life time of 20 years, compared to the 12-year life of the average diesel. Long-term repairs on their trolley buses are generally less costly than on diesel buses. The everyday wear on the propulsion system of a trolley bus is considerably less damaging than the everyday wear on a combustion engine.

Fuel cost is at the time being higher for the trolley bus than for the diesel bus, but in 1990:s, when they purchased new trolley buses, the RTA estimated that fossil fuel prices would be more costly than the purchase of electric power. However, this has not been the case. Today the energy cost for trolley bus is slightly higher than for a diesel vehicle. The operating costs in Dayton are mostly covered by state subsidies (9%) and tax levy (65%) and only 16% by fares.

5.4 São Paolo

System

The largest trolley bus system in counts of km and number of buses is found in São Paolo, Brazil. The trolley bus system service in São Paolo is divided upon two operators who together have 552 buses. SPTrans have about 480 trolley buses and 18 trolley bus routes, which altogether range 453 km.

The EMTU operates outside the city's boundaries and has about 70 trolley buses, which operate on 4 routes ranging 37 km. This network, known as the Medium Capacity Network, opened in 1989/90.

The fleet of trolley buses in São Paolo is divided upon three generations. The first generation of trolley bus, 79 buses, has an electro-pneumatic traction control with comes axle (sheaf of spring). The second generation, 251 buses, has a chopper-thyristor traction control and pneumatic suspension. The third generation, 222 buses, has chopper-IGBT traction control and pneumatic control.

The trolley bus service in São Paolo is funded by fares (85%) and grants (15%). The relatively large proportion of fares in Saõ Paolo in comparison to other cities can be explained by different ways of show receipts and grants, but also lower labour costs, etc.

Development

During the last 3 years, 111 new trolley buses have been purchased to the city by SPTrans. The 284 "second generation" vehicles, which are driven by chopper-thiristor-technology, have also been renewed as well as 2 articulated buses for a new transport modality of medium capacity, VLP, in Brazil. The VLP stands for light vehicle above tyres.

On a short-term perspective, the SPTransport Company is working on the renovation of the existing overhead wire, which is 264 km long. They intend to complement the system with new lines and increase the net by 23 km. On a long-term, the forecast is to increase it another 27 km.

Problems and benefits

The main problem that Sptrans experience is the reliability of the system. As the net implies restrict mobility, any failure, even those who require a simple solution, cause disturbance on the operation. However, the problem has been mitigated as the technology of the trolley buses has improved. The renovation of the current fleet and the adoption of a new traction system, chopper IGBT, has decreased the number of failure from 2 000 km per failure down to 12 000 km per failure.

The experts on SPTrans all agree on the advantages of the trolley bus. The main benefits listed are that the trolley bus is a non-polluting vehicle and has a low noise level.

Costs

Both the cost of introduction with infrastructure and the energetic cost are higher than other transport modes. The energetic cost of the trolley bus is 0.38 USD/km, compared with 0.20 USD/km for a diesel bus and 0.26 USD/km for a natural gas bus. Despite this, the city of São Paulo argues that the advantages of the trolley bus are not to be questioned as the non-polluting transport they offer highly improves life quality in urban areas.

5.5 Lausanne

System

The population of the Swiss town Lausanne is 244 000 people. Although it is not a big city, they have a fleet with 111 trolley buses. During peak-traffic 95 buses operate in the town. The buses are of standard model of which about 60 of them have a trailer connected to them. The trolley bus with trailer can take 80+70 passengers and is about 28 metres long. The trolley bus operates on 11 routes, which have a total length of 61 km.

The trolley buses constitute an essential part of the public transport system in Lausanne. About 63 million people travel by public transport every year. Eric Kehlhofer at the public transport office in Lausanne estimates that almost 2/3 of the trips are made with trolley bus. The average speed of the trolley buses is 15 km/h.



Figure 5.5.1. The trolley bus in Lausanne (photo: PG Andersson).

Development

The overhead system is maintained regularly, but no new investments have been made the last decade. They have the same rectifiers as when the trolley bus was introduced into the town. The trolley buses are in average 15 years old. No investments have been made on new buses the last decade. The system has not expanded in terms of routes or kilometres the last decade.

The fleet is to be modernised in one year or so, around the year 2000. The fleet will then be totally renewed. The replacement of buses will imply a reduction of the total fleet. They will not have any extra standby buses. If a trolley bus needs extra maintenance and has to be put out of traffic for a while, they will instead replace it with a diesel bus. The reduction will not affect the number of trolley buses in operation. They will probably buy articulated trolley buses. 27 of the buses will be dual mode buses from Neoplan, which will be delivered in the year 2000.

A computer-controlled monitoring system has been fitted to 111 of the trolley buses.

Problems and benefits

The main benefit with the trolley bus is that negative impacts on the environment, such as pollution and noise is avoided or reduced. People are more and more positive as the environmental concerns become greater and more important politically. They have not done anything special to mitigate the negative visual impact.

The problems connected with the trolley bus are the same in Lausanne as in the other cities. One other difficulty that Lausanne has is that they can not use the trailers in wintertime, when there is snow, because they slip.

Cost

The total cost of running a trolley bus in Lausanne is more expensive than running a diesel bus, but on the other hand, it is less expensive than tram. The energetic cost between a diesel and a trolley does not differ so much, but the investment cost is much greater for the trolley.

5.6 The role of the trolley bus

In both Dayton and Vancouver, there is nostalgia about the trolley bus. The city of Dayton has had trolley buses since 1937 and Vancouver celebrated the systems 50:th anniversary in 1998. In both cities, the environmental concern is of great importance. The government also reimburses transportation agencies utilising fixed guideway, such as trolley bus systems. For RTA in Dayton, this represents about 4 million USD annually in operating funds. The reasons for extending the system are hence not only environmental, but also traditional.

In Athens, the great problem with air pollution was one of the main reasons for the development of the trolley bus system. Environmental investigations presented at a seminar in 1990² showed that the diesel buses in Athens contributed to 20-40% of the air pollution. This investigation led to a plan aiming to replace diesel bus with trolley bus and the system is now extending. Other options such as metro and light-rail were investigated, but the risk of vibrations and archaeological findings made the metro alternative less attractive. As the tram is more expensive than the trolley bus, which is also well suited for the narrow and steep streets in Athens, the trolley came out as the best alternative.

In São Paulo, the environmental benefits of the trolley bus are also considered very important. If they did not already have the system they would still invest in one and promote it in a big way, says a representative from the city.

Problems and benefits

The main problems with trolley buses according to the five cities are:

- Overhead breaking and failure of power
- Can not pass traffic obstacles
- High capital cost for the vehicles and infrastructure
- Damaged poles and overhead wires caused by automobile accidents
- Trolley shoes wearing too quickly
- Little flexibility in changing or modifying routes
- Old DC chopper technology is maintenance intensive (Vancouver)

Today many trolley buses are not accessible for the handicapped, which can be seen as a result of that, the vehicles have a longer-life time and hence old models are still running the streets.

Many problems related to power supply are solved with the new technique, where the buses have an emergency power battery. The emergency battery enables more flexibility in changing of routes in case of an accident or in case of failure of power.

The main benefits are:

- Free of pollution
- Good image to the public
- Longer vehicle life time
- Quiet
- Good acceleration under load

One of the main benefits with trolley buses is that they can have a good image to the public. This means that the trolley bus as well as the tram

² Transport and Environment in Developing Countries, proceedings of a seminar in Sussex, England 10-14 sept 1990.

has a clearly distinguished, not changeable, route system. This often have a good effect on the public opinion about the reliability.

Negative visual impacts

One of the disadvantages with trolley buses is that the infrastructure (poles, wire, rectifier stations) can have a negative visual impact on the environment. This problem can be mitigated by different means. Poles and wires may then be avoided for short distances. The design of the infrastructure is of great importance. Instead of using poles, the wires can be fastened in house walls or in already existing poles, such as lampposts. The design and colour of the poles can be made more or less beautiful. It is important that the streetscape is seen as a whole.

A trolley bus system with a battery for energy storage can be a solution if there are some areas that are especially sensitive for visual intrusion. In Vancouver, they use feederless systems on all new lines. The rectifier stations of today are much smaller than the old ones. In Vancouver, all the old stations have been replaced by new ones, which has led to that they are more easily concealed.

5.7 Life time costs

In the beginning of the 90's, surveys done in Vancouver and Seattle show that the operating cost of a trolley bus was slightly higher than that of a diesel bus. BC Transit estimated in 1993 the cost of a brand new trolley bus to be 1.5 times that of a diesel bus. Today, the difference has increased to over 2 times, due to falling oil prices. The total cost of operating the trolleys (less operator wages) is at present about 0,75 USD per kilometre in Vancouver. This is high compared to an equivalent cost for diesel buses at about 0.31 USD per kilometre. These cost estimations do not include the initial capital costs. The cost of electricity is about 0,10 USD/km for the trolley bus and the diesel fuel cost is about 0,16 USD/km. To translate costs to the case of Hong Kong is difficult because of different taxes etc. A general comparison can be made by comparing the cost for electricity and diesel. The current cost of electricity in Vancouver (Canada) is about 3.8 cents/kWh and the diesel cost is about 29 cents/litre (including the taxes in Canada).

The city of Edmonton has calculated the average costs per kilometre over the last 10 years. The trolley bus has lower costs for power and maintenance, but the huge capital cost make the trolley bus more expensive than the diesel bus. The trolley bus costs 2.31 USD/km, compared with 0.97USD/km for the diesel bus.

The cost of trolley bus operation includes the cost of maintaining the overhead network and the higher initial cost of the vehicle, which is explained by the economics of mass production. The trolley buses, in comparison to the diesel buses have higher operating cost but lower

maintenance cost. However, the higher initial costs are offset by the much lower energy cost. In some cases, it can also be argued that trolley increases the patronage, which should be taken into consideration in the economic analysis.

Table 5.1 Average actual costs per km over the last ten years in Edmonton.

	Trolley Bus (USD/km)	Diesel Bus (USD/km)
Power/fuel	0.18	0.20
Maintenance	0.36	0.41
Capital (bus)	1.11	0.37
Overhead maintenance	0.36	
Capital (overhead system)	0.30	
Total	2.31	0.97

The RTA in Dayton stresses the fact that the average lifetime of a trolley bus is much longer than that of a diesel bus. The RTA's trolley buses have an average life time of 20 years, compared to the 12-year life of the average diesel. Long-term repairs on their trolley buses are also generally less costly than on diesel buses. Another thing in favour for the trolley bus is that the everyday wear on the propulsion system of a trolley bus is considerably less damaging than the everyday wear on a combustion engine.

Any introduction of the trolley if the infrastructure did not exist would be problematic according to Chris Lythgo at BC Transit. The barrier is the large relative capital costs required which are exacerbated by a probably higher life-cycle cost than for diesel buses. The environmental benefits would have to be carefully weighed in the decision.

A calculation by BC Transit in 1994/95 of the energy efficiency of the operating modes in Vancouver shows that the trolley buses is the second most efficient transport system, after the SkyTrain³.

A representative from San Francisco railway argued at the Seattle conference in 1983 that the costs of trolley system could be justified if we use a long-term perspective. The overhead wire and power supply equipment are long-lived. Trolley support poles with regular painting and underground feeder cable conduits can last indefinitely. Other components such as wire, overhead switches and rectifiers can last 35 to 70 years on moderate density lines.

In conclusion, it can be noted that the introduction of a trolley bus system often is a political question as it depends on how much the city values the environmental benefits. The hypothetical question to the five cities, whether they would introduce a system today if it did not already exist, is

³ Internet homepage of BC Transit.

therefore difficult for them to answer. The total cost for running a trolley bus system depends to a very large extent on local conditions, such as the price for labour and taxes. The definition of receipts and grants can also make a difference to what is presented as actual costs.

6. Conclusions

The environmental benefits of the trolley bus are important. If the city of Hong Kong on the short-term wants to achieve zero emissions in the public transport system, then the only way to go is through electric transport forms. These transport forms can be either trolley bus, light rail or battery bus. The battery bus has a limited driving distance, whereas the trolley bus is not limited in range. The trolley bus is also cheaper than light rail, and most likely, the cheapest present zero emission option.

To ensure an optimal use of the infrastructure (wires, substations etc) it is necessary to concentrate the trolley bus routes, so that the routes are clearly distinguished. This also contributes to the simplification of the trolley bus net. To define the most suitable route alignment for the trolley bus, an overhaul of the bus system in Hong Kong will probably be needed. We would recommend a Road Network Analysis (RNA) in order to find out where the trolley bus routes could be of most use and thereby optimise the system. Furthermore, when the route alignment and traffic conditions are examined thoroughly it is also possible to obtain a detailed cost proposal on the system.

It has to be stressed that even if double decker trolley buses could be a technically viable solution, the incremental cost would be very high due to the increase in development cost. Likewise, the development and test period for a double decker solution would be long.

Although trolley buses have the ability to achieve zero emissions, it is unlikely that these buses could cover all the needs for public transportation. Buses with internal combustion engines would have to be used as a complement to trolley buses in the foreseeable future. Consequently, a complete public transportation system that has zero emissions is presently not achievable. Trolley buses that can replace some conventional buses (say 30 %) is one of the options. Other options, such as alternative fuels (alcohols, LPG and CNG) and improved diesel fuel quality in combination with exhaust aftertreatment (catalysts and filters), should be investigated as well. It is of interest that the total mix of emission levels for the used transport units in certain urban area is cost-effective. The total mix of emission levels for the used transport units in a certain area gives the total pollution load. For being cost-effective, the total public transportation system should maximise the environmental benefit for a certain cost.

On the long-term horizon, zero or near zero emission options should be investigated. Possible options are ultra-low emission conventional piston engines (run on alternative or reformulated fuels), hybrid drive systems or fuel cells. Battery buses could be a viable option on short distances but due to the limited range, this alternative has to be considered as a niche solution.

I. *Manufacturers of trolley buses*

Trolley bus models

The most important trolley bus manufacturers from whom we have received information.

Manufacturer	Contact person	Adress	Phone /fax number
Skoda Ostrov ⁴ (Czechoslovakia)	Václav Novák	Dolni Zd'ár 43 363 29 Ostrov	Phone: + 420 164 677347 Fax: + 420 164 612641
Neoplan (Germany)	Norbert H. Fischer	Valhinger Straße 118-122 705 67 Stuttgart	Phone: + 49 711 7835 357 Fax: + 49 711 7835 331
Ikarus (Ungary)	Janos Stromajer	Margit str. 114 H-1165 Budapest	Phone: + 36 1 252 9568 Fax: + 36 1 383 5958
Van Hool (Belgium)	Paul Jenné	Bernard Van Hoolstraat 58 B-2500 Lier Koningshooikt	Phone: + 32 3 420 20 20 Fax: + 32 3 482 30 68
Hess (Switzerland)	H. Naef	Bielstrasse 7 CH- 4512 Bellach	Phone: +41 32 617 34 11 Fax: + 41 32 617 34 00
MAN/ÖAF ⁵ (Austria)	A. Neürer	Brunner Straße 44 A-1231 Wien	Phone: + 43 1 866 31 Fax: + 43 1 866 31

⁴ AAI transportation works together with Skoda in a US oriented company, ETI.

⁵ ÖAF is part of the MAN-group.

II. Manufacturers of electrical equipment

Traction equipment

Many of the trolley bus manufacturers use Kiepe elektrik for the electric equipment and traction technique. MAN/ÖAF, Neoplan, Van Hool, Ikarus, Hess have all used Kiepe the last 20 years.

Manufacturer	Contact person	Adress	Phone/fax number
Kiepe elektrik (Germany)	A. Winkler	Bublitzer Straße 28 D- 40599 Düsseldorf	Phone: + 49 211 7497 310 Fax: + 49 211 7497 419

Power supply and overhead wire system

The most important manufacturers of power supply and overhead wire systems from whom we have received information are listed below.

Manufacturer	Contact person	Adress	Phone/fax number
Adtranz (Sweden)	Stefan Widell, Anders Engström	S- 721 73 Västerås	Phone: +46 21 32 22 06 Fax: +46 21 12 35 43
Furrer+Frey (Switzerland)	Yvonne Clough- Bäckström	P.O. Box 182 CH-3000 Berne 6	Phone: + 41 31 351 61 11 Fax: +41 31 351 62 35
Kummler+Matter (Switzerland)	R. Jäck	Hohlstr. 176 CH- 8026 Zürich	Phone: + 41 1 247 47 47 Fax: +41 1 247 47 77

III. Questionnaire to the manufacturers

1. What different types of trolley bus vehicle do you market?
(standard two-axle buses, articulated buses, dual mode, double deckers...)
2. Description of the vehicle types, some basic technical data on the different types, such as: length, width, passengers, max speed, vehicle climbing capacity, voltage, power supply...
3. What kind of drive-train technology is used for the different vehicles?
(Drive shaft, wheel-hub motors, Siemens ELFA-system,...)
4. Do you have dual-mode vehicles?
If yes, which type?
5. Have you delivered any trolley buses lately? If yes; which type, how much did they cost and to which city were they delivered?
6. What about the latest developments of trolley bus vehicles? What are the trends?
7. Prices on your different trolley buses in round figures.
8. Expected lifetime of your trolley buses.
9. Do you have any calculated lifetime cost for a trolley bus compared with diesel buses?

Additional question:

Would it be possible to build a double decker trolley bus?
