

# Biomass-based synthetic fuels as an integral part of Volkswagen's fuel strategy and the RENEW project

Frank Seyfried

Synbios Conference, Stockholm, 18th May 2005

# Global Challenge ???

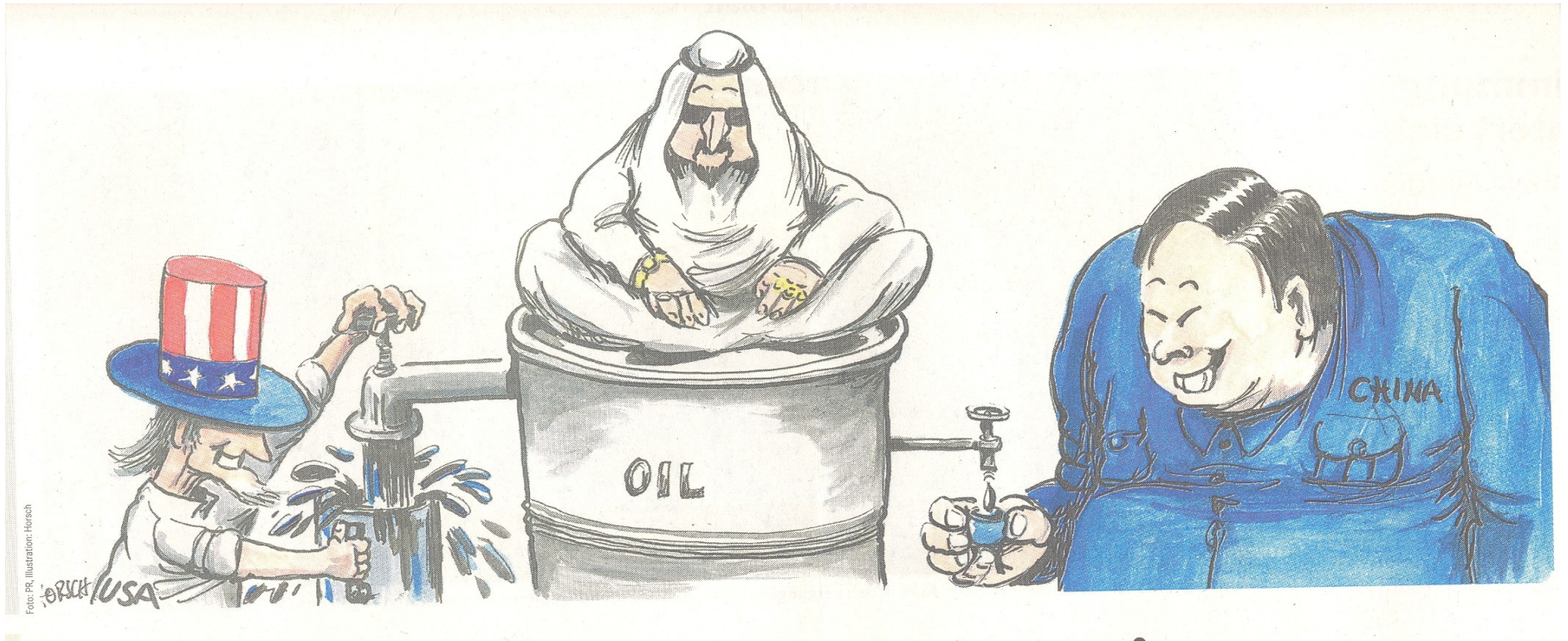

**Increase in passenger car fuel consumption 2004:**

**India: 10%**

**China: 15%**

**Indonesia: 3 %**

**EU: 1,2%**

**USA: 0%**

# Volkswagen Golf Diesel

## First Diesel: Golf I 1976



<b>cylinder number</b>	<b>4</b>
<b>displacement</b>	<b>1,5 l</b>
<b>power</b>	<b>37 kW</b>
<b>rotational speed</b>	<b>5000 1/min</b>
<b>maximum torque</b>	<b>84 Nm</b>
<b>maximum speed</b>	<b>140 km/h</b>
<b>0 – 100 km/h</b>	<b>18 s</b>
<b>curb weight</b>	<b>780 kg</b>
<b>consumption</b>	<b>6,5 l/100 km</b>

## Latest Diesel: Golf V 2003



<b>cylinder number</b>	<b>4</b>
<b>displacement</b>	<b>2,0 l</b>
<b>power</b>	<b>103 kW</b>
<b>rotational speed</b>	<b>4200 1/min</b>
<b>maximum torque</b>	<b>320 Nm</b>
<b>maximum speed</b>	<b>203 km/h</b>
<b>0 – 100 km/h</b>	<b>9,3 s</b>
<b>curb weight</b>	<b>1400 kg</b>
<b>consumption</b>	<b>5,5 l/100 km</b>

# Conclusions

- ➔ **resolute additional improvement of powertrain efficiency with simultaneous emission reduction**
- ➔ **including of alternative energy sources in fuel production**
- ➔ **development of CO<sub>2</sub>-neutral pathes in vehicle usage**

# Volkswagen Fuel- and Powertrains Strategy

Dr. Heinrich/UOP R&D Refining Panel / 19.5.2005

**Diesel, Gasoline  
fossil Basis**

**SynFuel  
GtL / CtL**

**SunFuel®  
renewable**

**Hydrogen  
renewable**

**TDI, FSI**



**Hybrid,  
TDI, TFSI**



**Combined  
Combustion  
System**



**Fuel Cell**

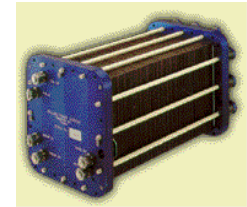

# Characterization of Synthetic Fuels

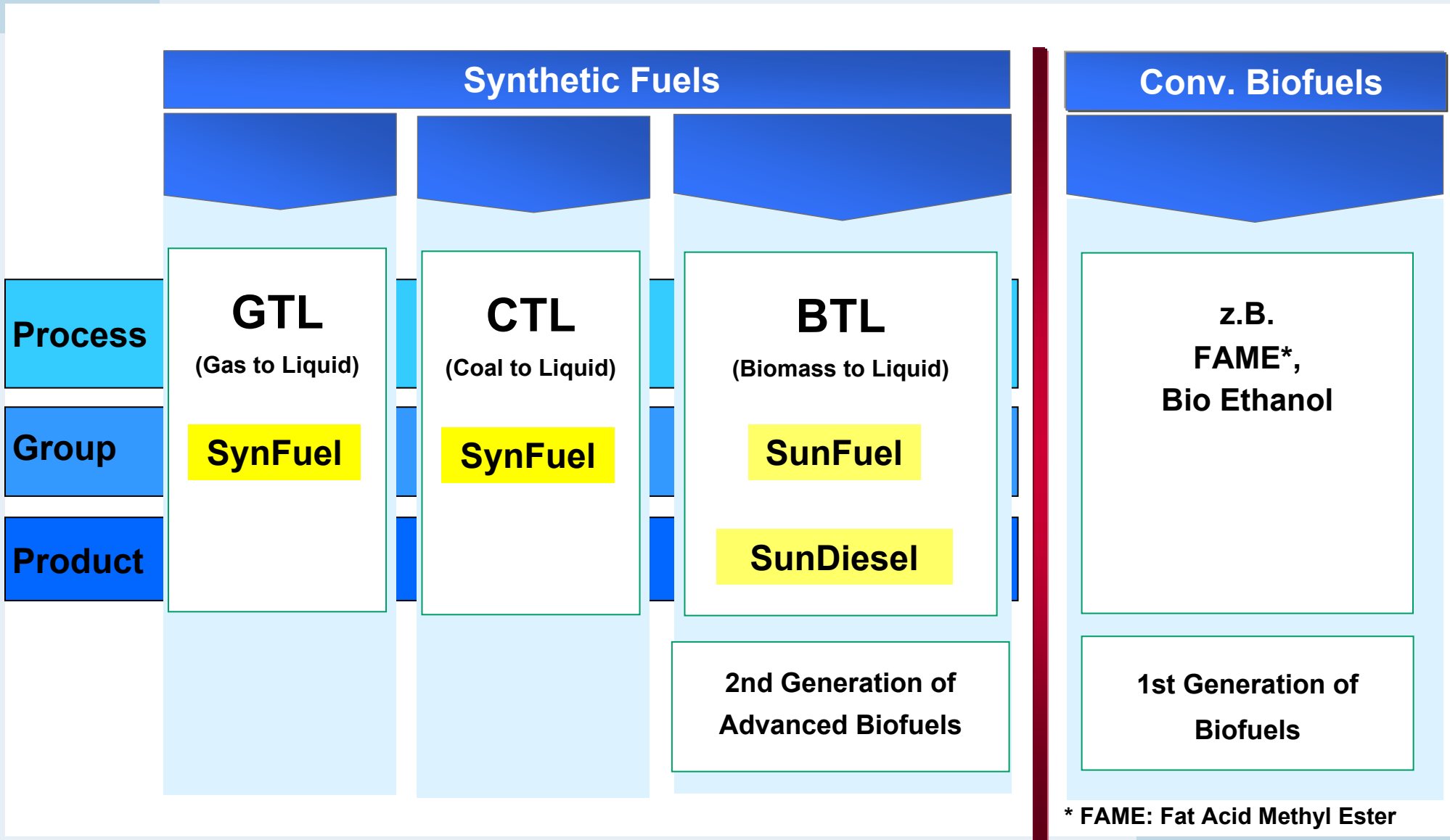

\* FAME: Fat Acid Methyl Ester

# Fleet Test Trial with GtL Berlin

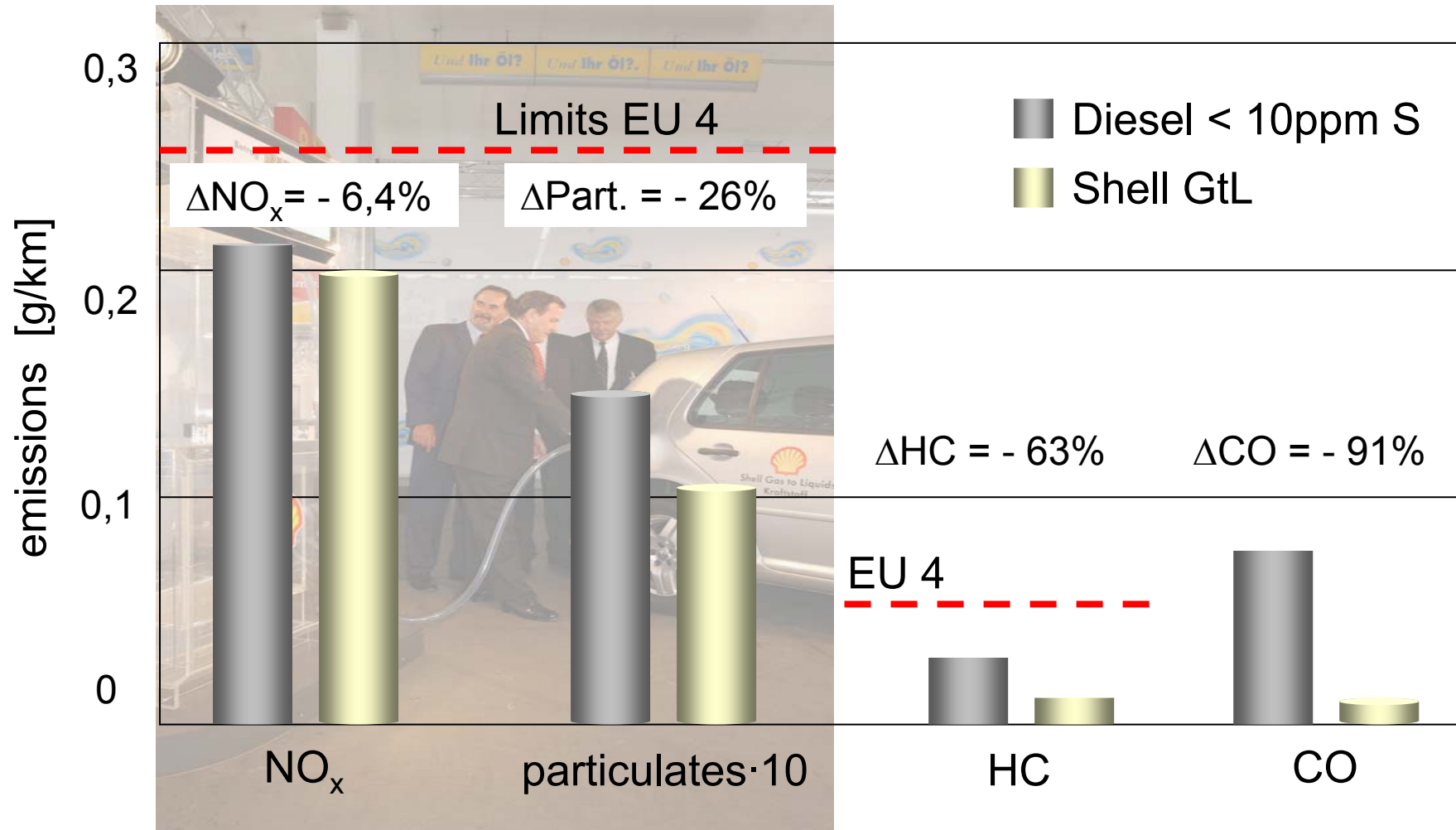

# Synthetic Fuels: Categories of Improvement

**1. Direct improvement of local air quality by usage of synthetic fuels in existing vehicles based on the outstanding purity of the fuels**

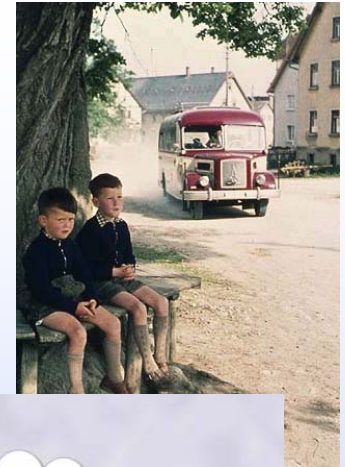

**2. Reduction of global CO<sub>2</sub>-emissions if biomass is used as primary energy for synthetic fuels**

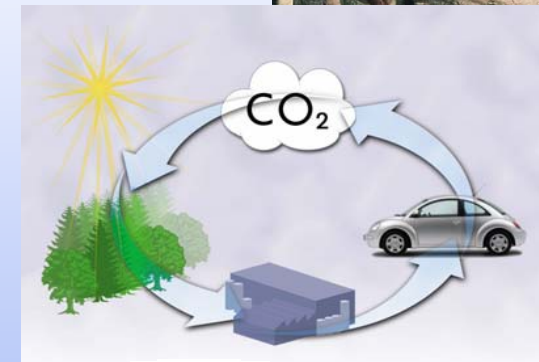

**3. Possibility to develop new combustion systems with widely improved characteristics based on the designability of synthetic fuels**

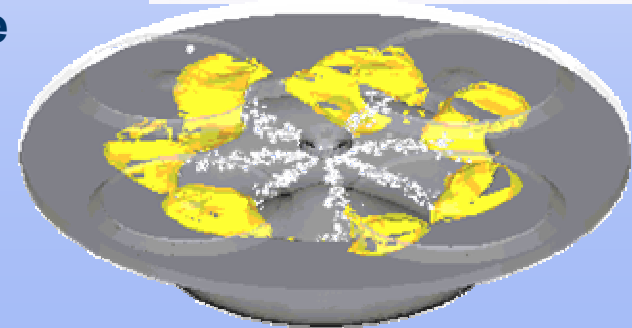

# CO<sub>2</sub> cycle with SunFuel®

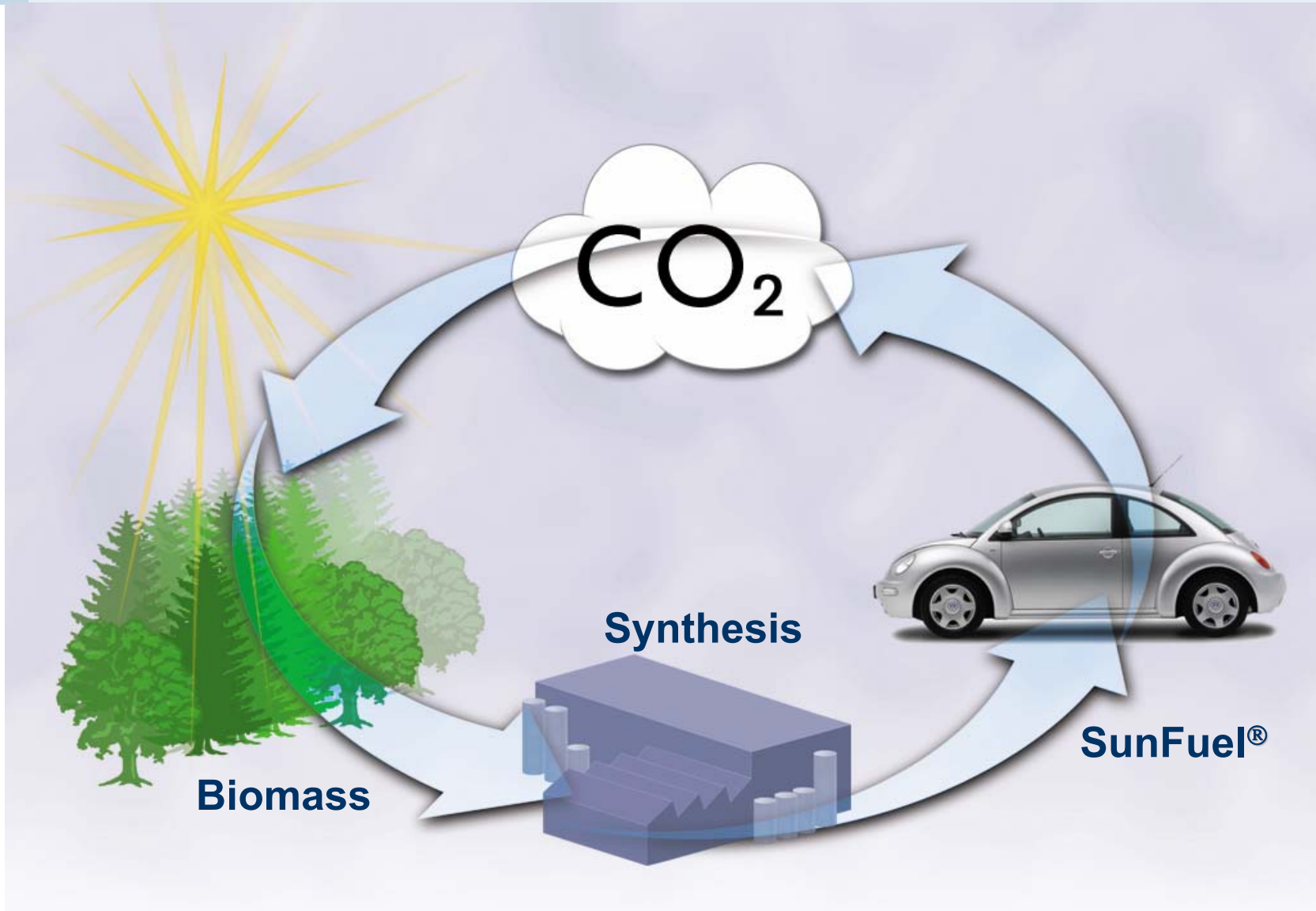

# Liquid Biofuels

litres per year and hectare



1,653 l gasoline equivalent



3,101 l diesel equivalent



1,183 l diesel equivalent



1,254 l diesel equivalent

Source: FNR (Fachagentur Nachwachsende Rohstoffe, Germany)

# Biomass Potentials in EU 30 in 2020

Dr. Heinrich/UOP R&D Refining Panel / 19.5.2005

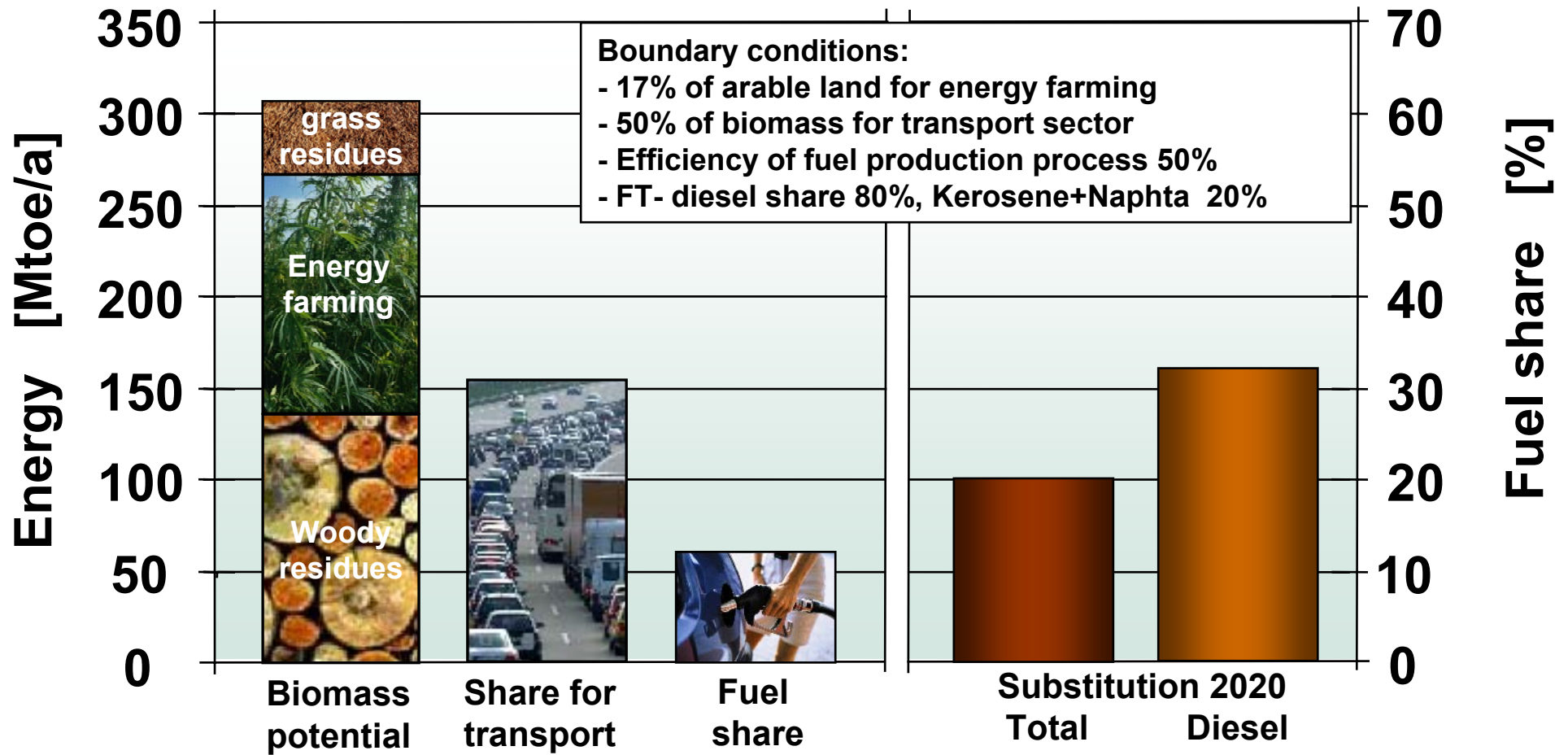

source: IE/LBST/VW

# Biomass to Liquid Fuel Production via Fischer Tropsch Synthesis

Dr. Heinrich/UOP R&D Refining Panel / 19.5.2005

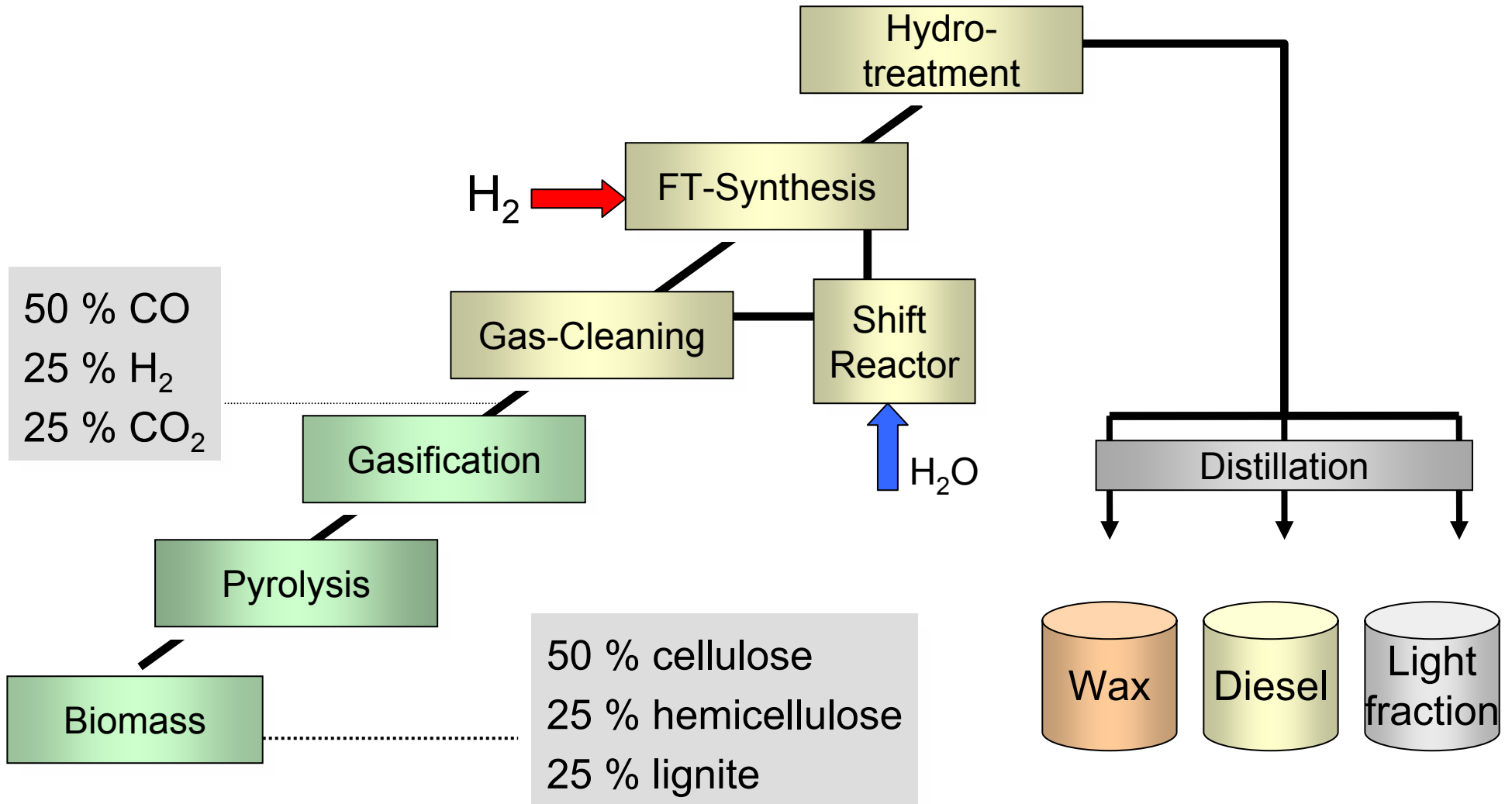

# CarboV<sup>®</sup> Test Facility CHOREN

Capacity: 1 MW thermal  
Input: Wood  
Straw  
Green plants  
Shredder-Light-Fraction  
Coal

Products:  
earlier: BioSynGas → el. Power  
Methanol  
Kerosene  
today: Diesel appx. 600 ltr/day



## Renewable Fuels for Advanced Powertrains

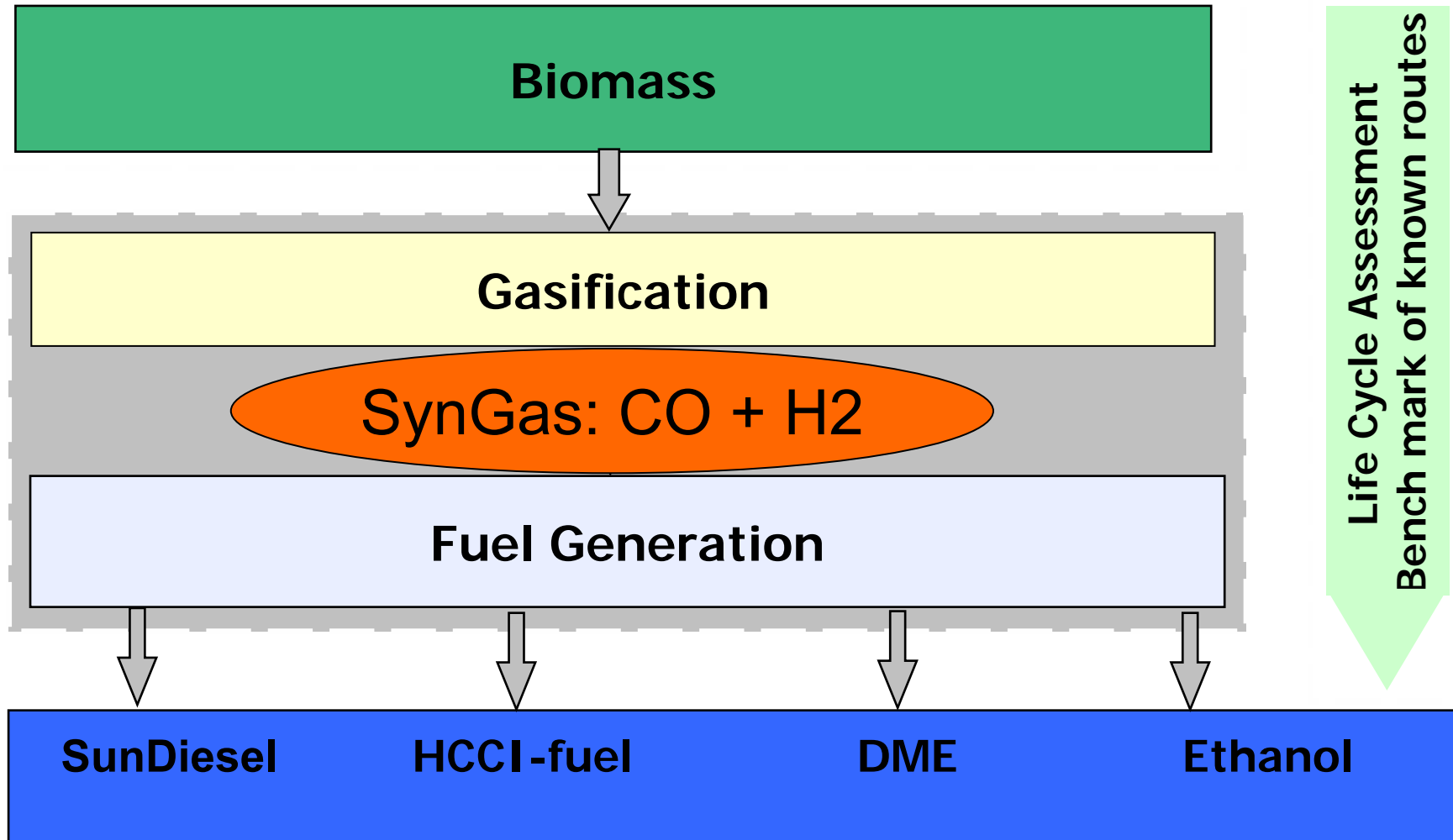

**SP 1**

**OPTIMISED FUELS  
for new drive trains**

**SP 2**

**OPTIMISED PROCESS  
for FT- fuel**

**SP 3**

**DME production  
from black liquor**

**SP 4**

**Optimisation of  
bioethanol production**

**SP 5**

**Biomass and process  
assessment**

- biomass potential
- life-cycle assessment
- economical impact
- suitability for ICEs
- production assessment

**Training**

2 summer schools

**SP 6**

# Potential in HCCI combustion (SP 1)



## Preliminary Results about fuel effects



**RENAULT**

n = 3700 r.p.m. Influence of GTL fuels on Soot emissions

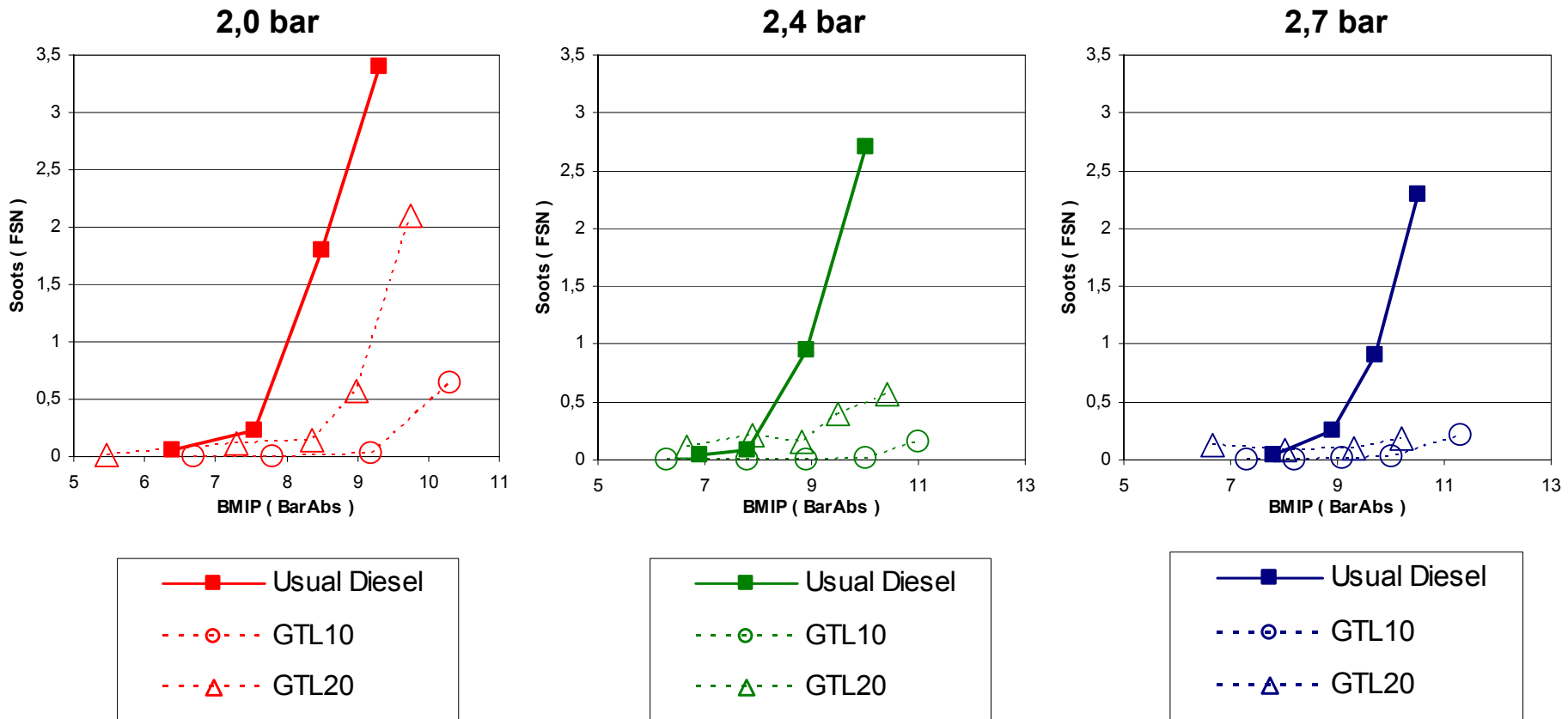

# Emission Results with BtL (SP 1)



Golf V, 2.0 TDI 4V 103kW,  
emission regulation: EU IV

3 measurements:

- diesel application
- + 2 adjustments
- minimised NO<sub>x</sub>
- minimised Part.

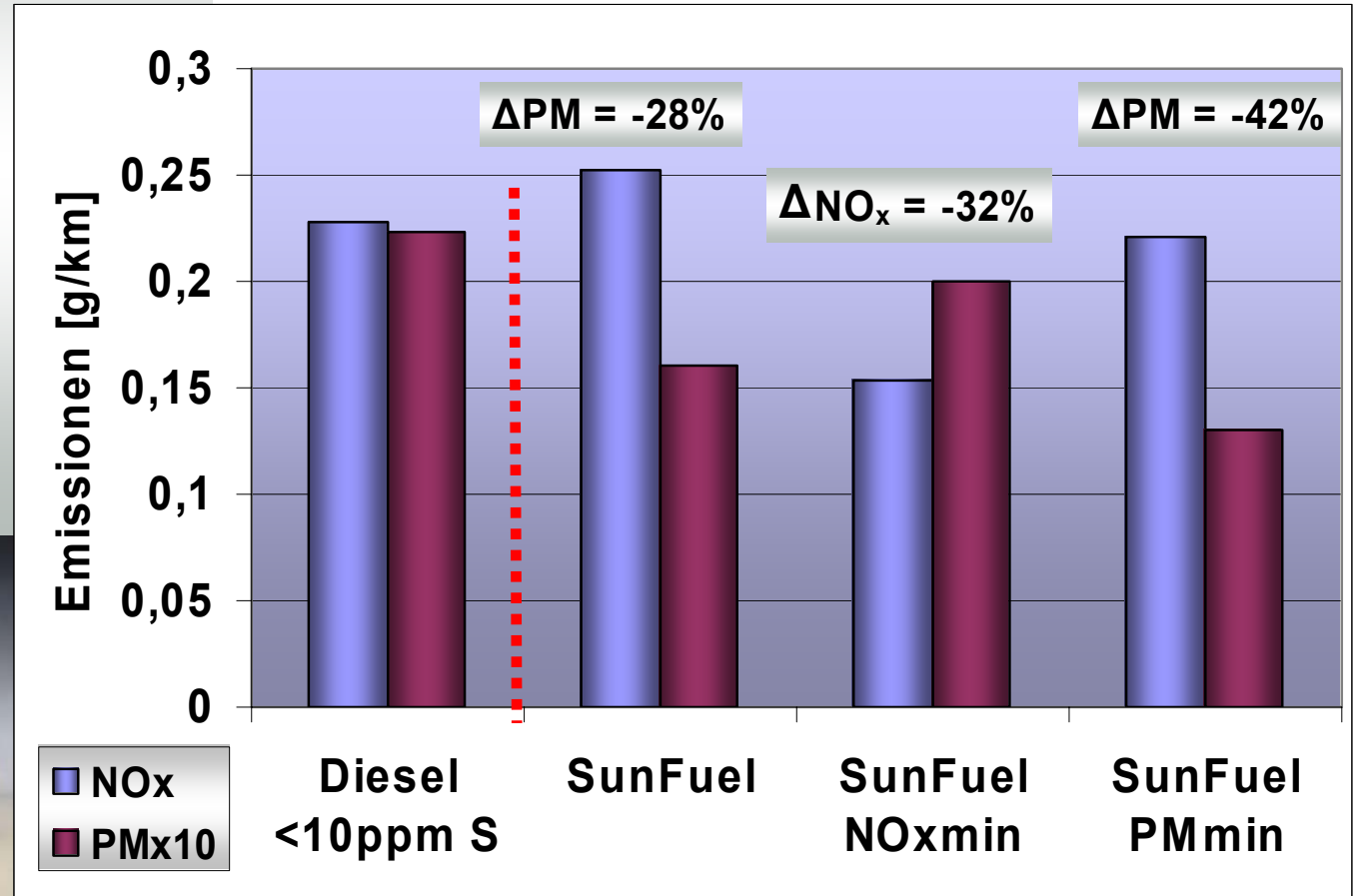

# Güssing FT - Slurry Reactor (SP 2)

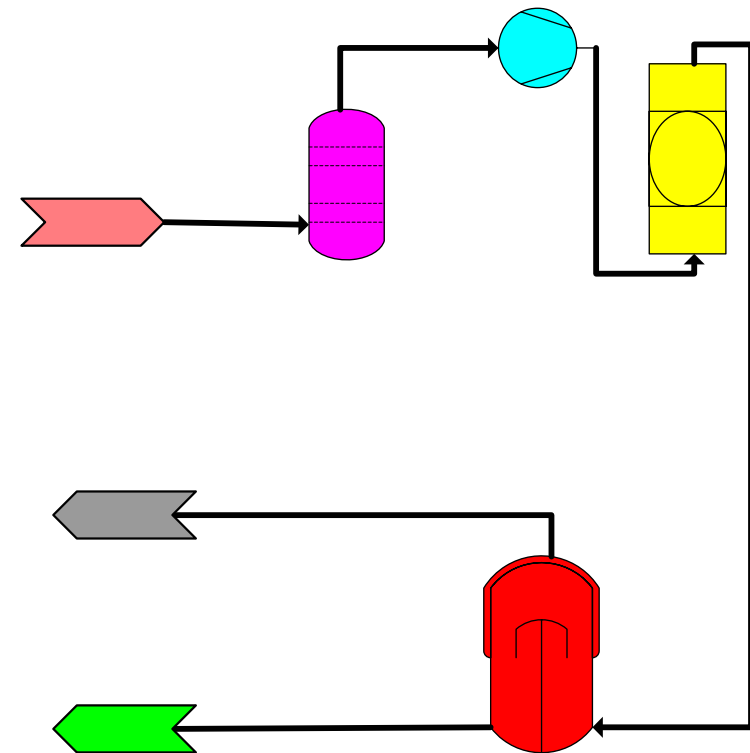

- Planning, construction engineering and build-up of Fischer Tropsch synthesis at existing plant in the first 18 months
- First fuel delivery planned for month 18
- Activities are according to plan

# Fast Pyrolysis and Gasification (SP 2)



Dr. Heinrich/UOP R&D Refining Panel / 19.5.2005

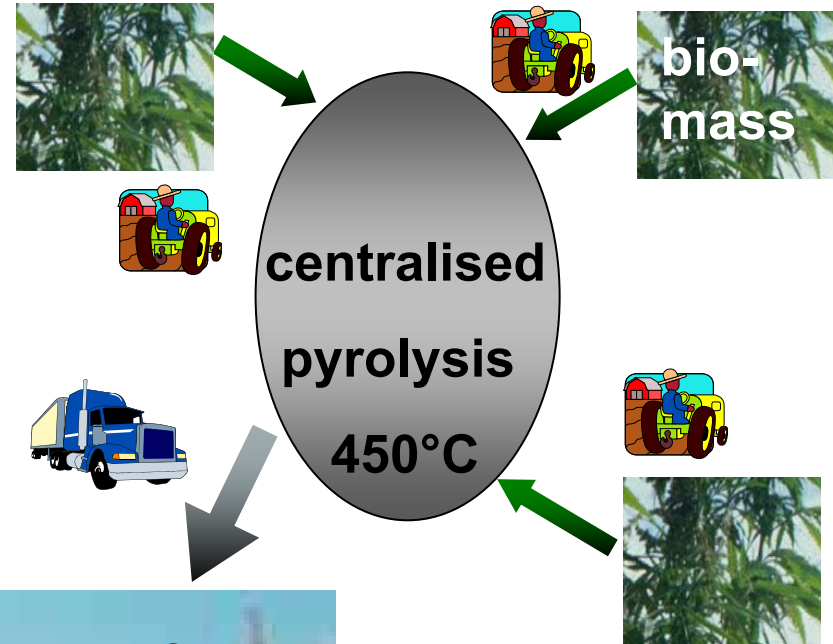
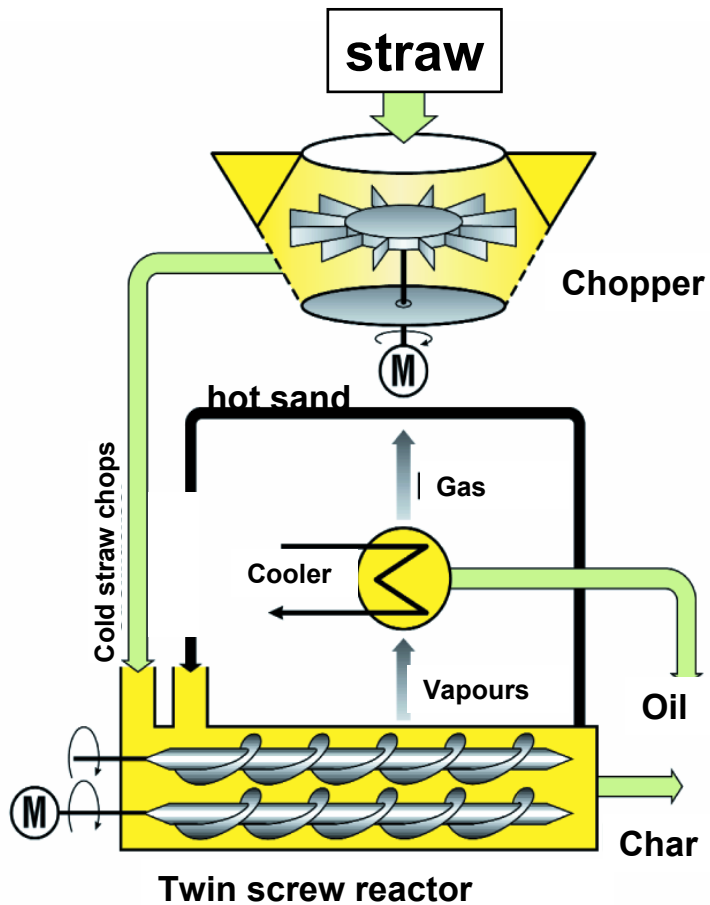

**gasification refinery**  
e.g. 200 MW - 1 GW  
related to biomass

# Black Liquor Gasification (SP 3)

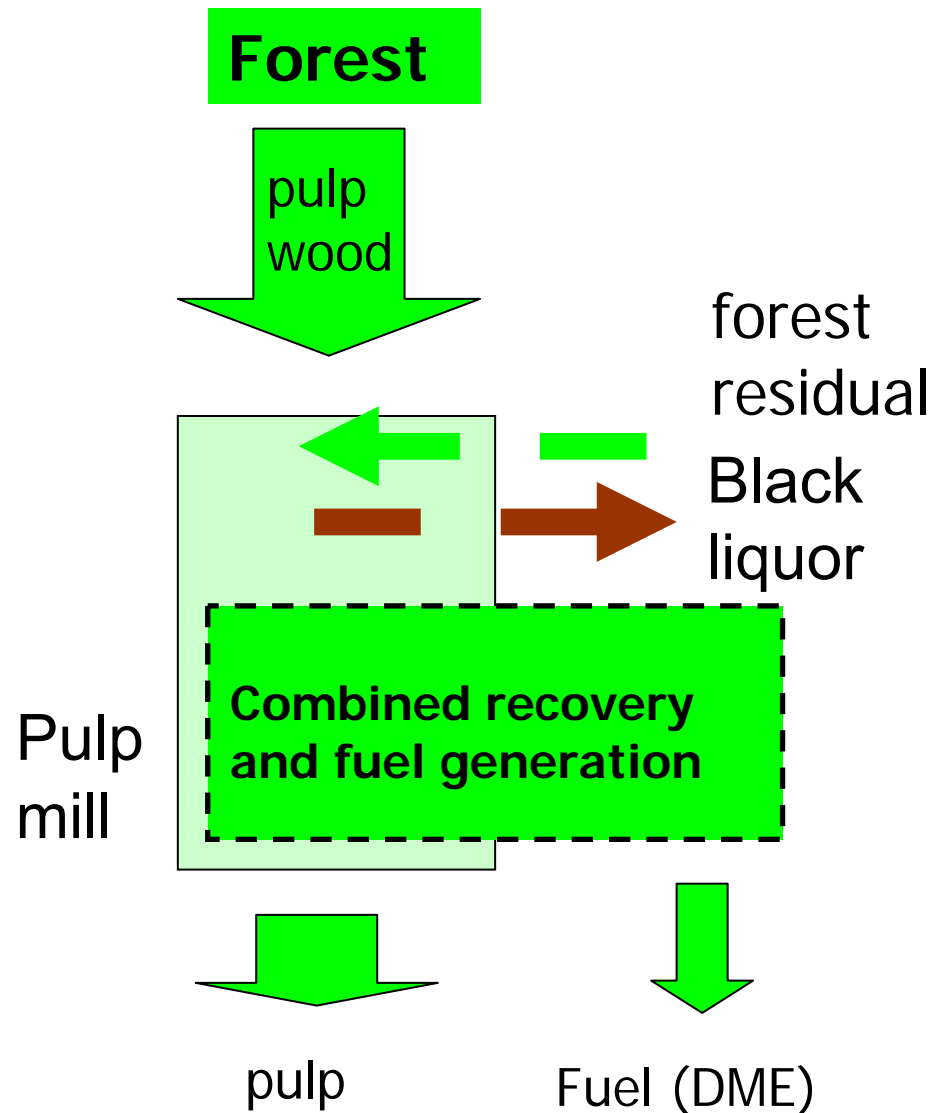

- data of the pilot gasification unit has been evaluated:

H<sub>2</sub> : 31 %

CO : 23 %

H<sub>2</sub>S : 2 %

CO<sub>2</sub> : 32 %

N<sub>2</sub> : 12 %

- 2 alternatives in DME production are assessed at the moment: two step or one step by Haldor Topsoe

# SP 5, WP 1 Biomass Potential Europe (Today)

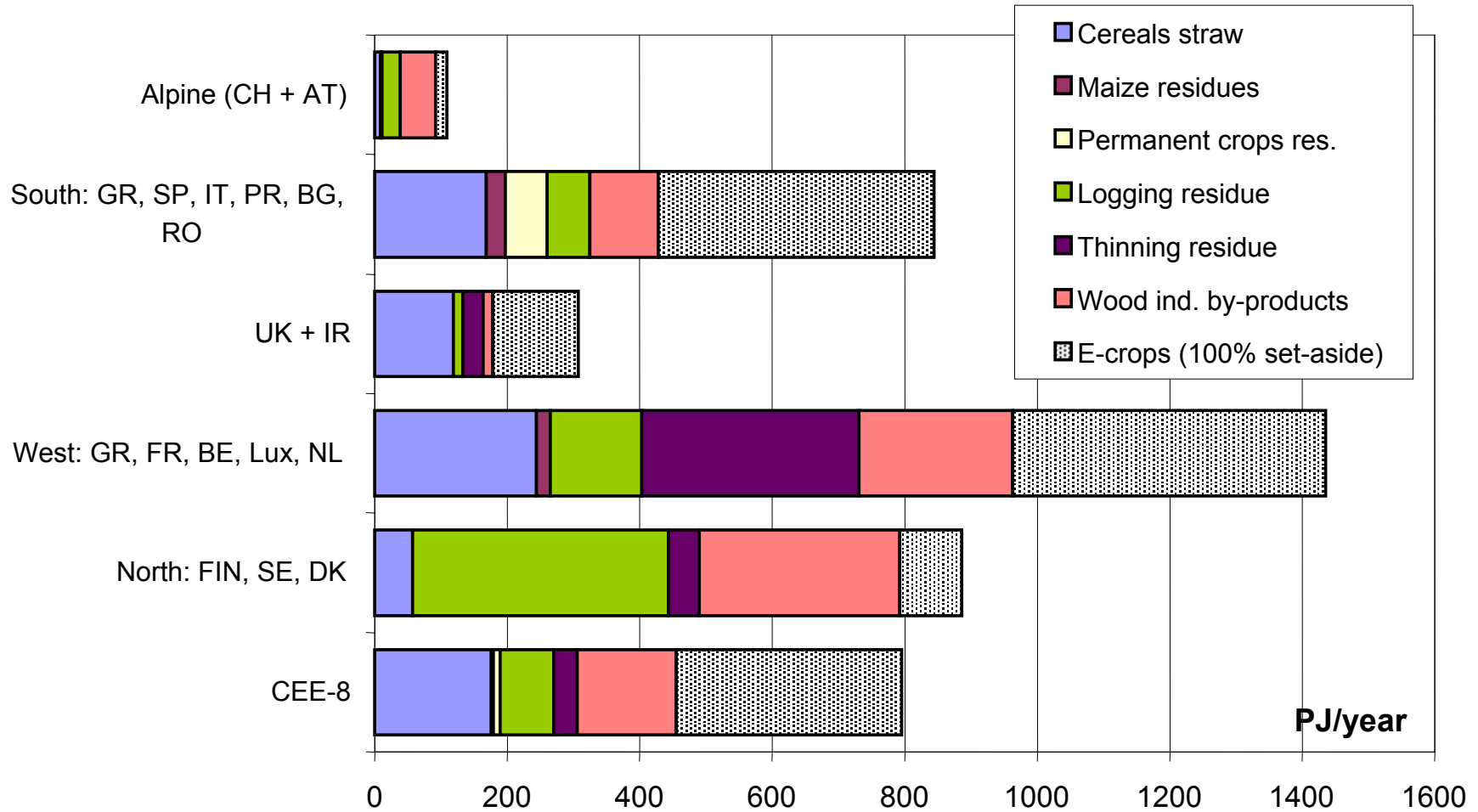

Total: approx. 4400 PJ/year = 100 Mtoe

# Renew Schedule



Dr. Heinrich/UOP R&D Refining Panel / 19.5.2005

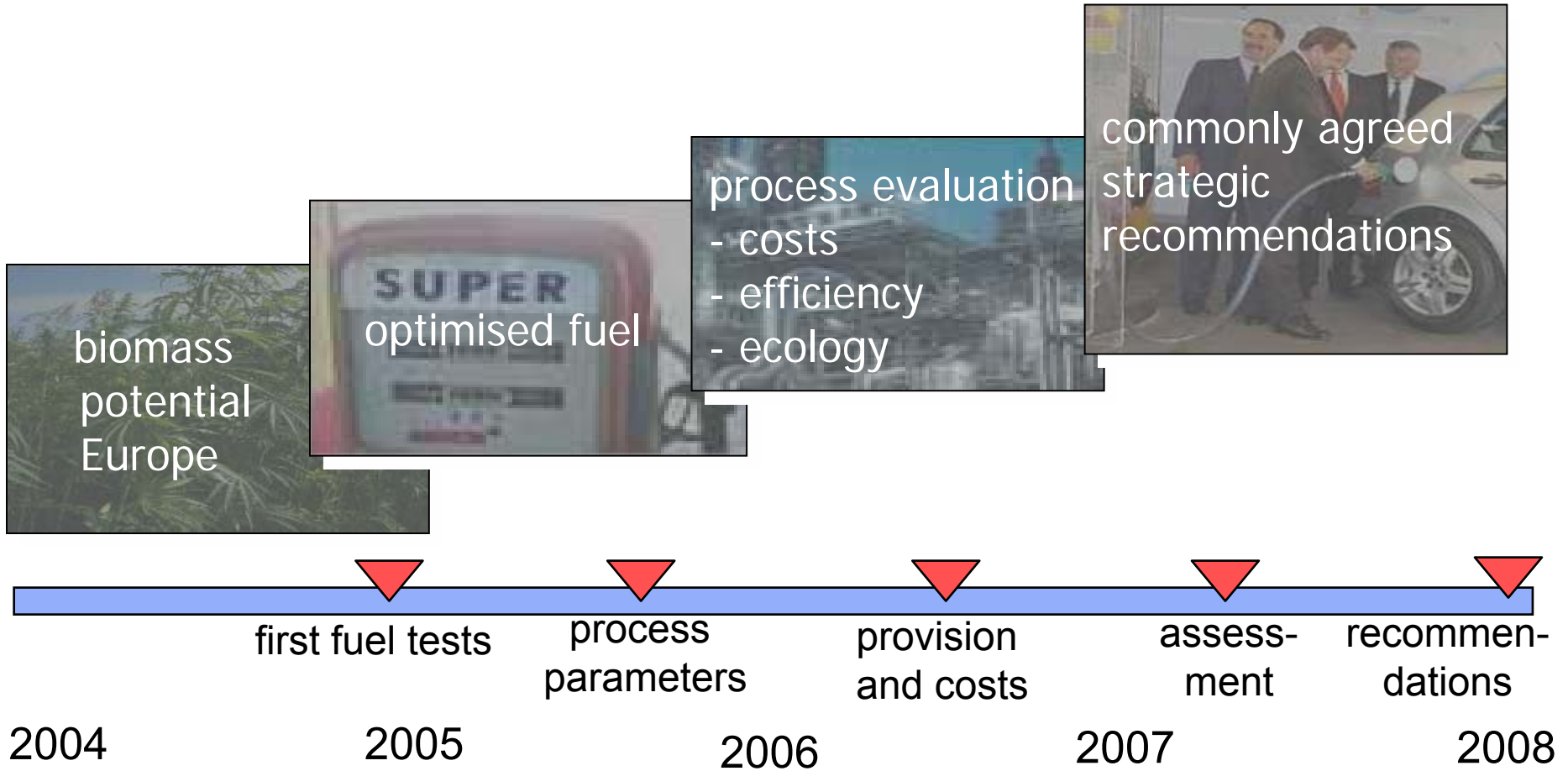

# Roadmap to BTL and Hydrogen

Dr. Heinrich/UOP R&D Refining Panel / 19.5.2005

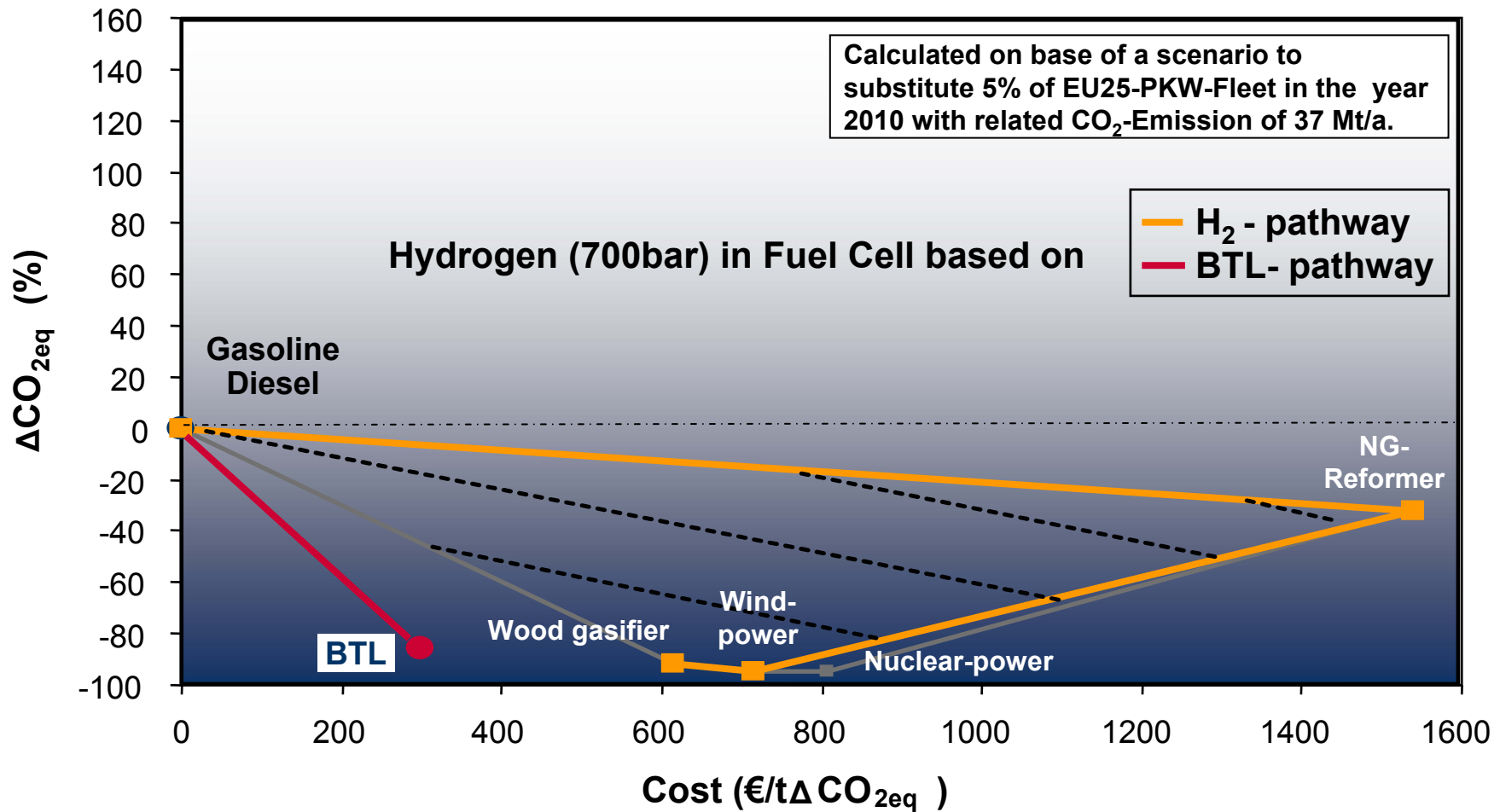

I thank you for your attention

